



TRAINING OF MASONS ON HAZARD-RESISTANT CONSTRUCTION



National Disaster Management Authority

Duration : 48 hours (6 days) | Classroom : 19 hours | Practical : 25 hours | Assessment : 4 hours

Training of Masons on Hazard-Resistant Construction

Duration : 48 hours (6 days)
Theory : 19 hours
Practical : 25 hours
Assessment : 4 hours



National Disaster Management Authority



Unnati
Organisation for Development Education



People in Centre

2018

Training Design and Resource Material Preparation:
People in Centre Consulting

Supported by:
Unnati- Organization for Development Education

Mandated and Commissioned by:
National Disaster Management Authority (NDMA)
Government of India

Disclaimer: The resource material provided in this document is taken from various sources for the purpose of training. No claim of ownership is being made by National Disaster Management Authority, Unnati and People in Centre Consulting. We are thankful to the contributing experts for this material. Their work is immensely useful for developing a better understanding of Hazard-Resistant Construction and is being used only for educational purposes. Any acknowledgement for further use of this material should be made to the original sources and authors. The views expressed in this document are those of the contributing experts and do not necessarily represent those of National Disaster Management Authority.

Training of Masons on Hazard-Resistant Construction



National Disaster Management Authority



Unnati
Organisation for Development Education



People in Centre



सत्यमेव जयते

प्रधान मंत्री
Prime Minister

MESSAGE

Masons play critical role in construction of peoples' houses and other buildings in rural and urban area. For most of the owner-led construction, masons and small contractors are not only builders but also architects and engineers. Appropriate knowledge and skills can make our houses and buildings safer during natural hazards.

Priority actions such as investing in disaster risk reduction and enhancing disaster preparedness in accordance with Sendai Framework for Disaster Risk Reduction include such initiatives for skill development of masons. To achieve the global and national targets of reducing disaster mortality and damage, it is critical that our houses and infrastructure are constructed incorporating hazard resistant principles and features. Therefore, capacity building of masons needs to be taken up in a planned manner to ensure safety during disasters.

I am glad that NDMA has developed this training curriculum and resource manual for trainers to ensure that skilled masons understand the principles and become proficient in various necessary techniques. The objective with which NDMA has brought out this curriculum and resource manual will be fulfilled only with cooperation of central and state governments, and coordination among all institutions involved in masons' training in adopting this curriculum as part of their programs.

I congratulate NDMA for this very useful and much needed initiative.

(Narendra Modi)

New Delhi
28 February, 2018

राजनाथ सिंह
RAJNATH SINGH

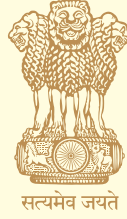

गृह मंत्री
भारत
नई दिल्ली-110001
HOME MINISTER
INDIA
NEW DELHI-110001

MESSAGE

Natural hazards impose considerable challenges for sustainable development as it impacts infrastructure, social and ecological systems adversely.

To ensure safe and resilient built environment, countries need to identify technologies, develop systems and standards and build capacities of engineers and masons.

It is heartening to note that National Disaster Management Authority (NDMA) in collaboration with UNNATI and People in Centre have evolved a curriculum and manual for training masons in disaster-resilient construction.

I am sure that this Manual will be useful in imparting requisite technical skills and building overall capacity of Masons for safe construction practices.

I am confident that this document will be extensively used and the result achieved will be far and wide for generation to come.

(Rajnath Singh)

किरेन रीजीजू
KIREN RIJIJU



गृह राज्य मंत्री
भारत सरकार
MINISTER OF STATE FOR
HOME AFFAIRS
GOVERNMENT OF INDIA



MESSAGE

Nearly 75 per cent of houses built in the country over last 10 years are burnt bricks wall constructions, thereby significantly raising the number of such houses across the country. This is especially true of rural India, where a majority of houses are non-engineered and built, more often than not, by untrained masons. Coupled with the fact that nearly 59 per cent of our landmass is prone to moderate to severe earthquakes, such houses are more susceptible to collapse in the event of an earthquake.

Against this backdrop, I am delighted to see that National Disaster Management Authority, in collaboration with 'UNNATI- Organization for Development Education' and 'People in Centre', has developed a curriculum and manual for training of masons in hazard-resistant construction adhering to norms of safety. This training manual will enable masons to construct resilient and sustainable houses, which will help to reduce the loss of lives and property due to disaster.

I am sure that institutions and stakeholders will integrate this module into their existing training programmes to give a fillip to the goal of a disaster-resilient India.

(Kiren Rijiju)

New Delhi.
06th February, 2018

Contents

Foreword.....	01
Acknowledgements.....	03
Background.....	04
1. Introduction	05
2. Training Curriculum.....	09
3. Training Schedule.....	36
4. Training Material	37
C1. Introduction.....	40
C2. Housing Typologies of India and Role of Artisans	46
C3. Hazards: Their Severity, Zonation and Impact on Buildings.....	60
P4. Quality of Materials and Importance of Tools	112
C5. Principles of Hazard Resistant Construction.....	128
C6. Hazards Resistant features for House Size and Configuration	152
C7. Importance of Site and Soil Conditions.....	162
C8. Hazard Resistant Features for Foundation and Plinth.....	182
P9. Constructing Sample Foundation and Plinth.....	204
C10. Hazard Resistant Features of Walls and Openings.....	210
P11. Constructing Hazard Resistant Walls.....	240
C12. Hazard Resistant Features of Roofs and Ceilings.....	244
P13. Constructing Hazard Resistant Roofs and Ceilings	268
P14. Field Visit: Rural House Construction and Materials Available.....	272
C15. Hazard Resistant Features of Roofs and Ceilings.....	280
C16. Estimation of Quantities and Costs.....	288
C17. Clarifications on questions	292
C18. Concluding Session.....	296
Bibliography	300

Foreword

Natural hazards like floods, earthquake, cyclone cause damage to vulnerable buildings leading to injury and life loss. Various house elements like foundations, walls, openings and roofs can be damaged if not constructed in compliance with building codes. Many a time the extent of damage can be so severe that it can lead to collapse of the structure and threaten human life. After a natural event, it is common to see exposed and sunk foundations, delaminated walls, separated and collapsed corners, cracks around openings, collapsed gable walls, failed columns and beams, displaced joists and rafters, blown roofing sheets. Such damage even if not life threatening can cause large economic loss putting affected families in distress. The poor and vulnerable families are always the worst affected.

One of the major contributing reasons for damage to buildings in natural hazards is non-adherence to norms of safe construction. In India, rural housing is largely non-engineered and built by masons. These masons provide comprehensive services to the owners including design, layout, engineering as well as construction. It is, therefore, of utmost importance that masons have good understanding of hazard resistant construction principles and are skilled with appropriate methods.

Ministry of Skill Development and Entrepreneurship (Government of India) is conducting mason training program under Pradhan Mantri Kaushalya Vikas Yojana. Construction Skills Development Council of India has prepared training curriculum and program for barbenders, electricians, carpenters, helper and semi-skilled masons, general masons and masons for concrete and other special works. Under Pt. Deendayal Upadhyay Gramin Kaushalya Yojana, Ministry of Rural Development is also implementing training program for carpenters, masons and barbenders. It is expected that this training curriculum and program prepared by NDMA is added to these existing mason training programs (all levels) to further enhance the skills towards incorporating hazard resistant construction features in the buildings particularly rural housing. Any other institution involved in skill development of masons can also adopt and add this training to their program.

This training program also responds to need of action by the local, national government articulated by Sendai Framework. Priority 4 is focused on strengthening disaster preparedness with 'build back better' concept through integration of disaster risk reduction measures. It also addresses the honourable Prime Minister's 10-point agenda, particularly the eighth point, delivered at AMCDRR 2016. In his words to build local capacity for disaster risk management, "Such efforts reduce risks and create opportunities for local development and sustainable livelihoods. Localization of disaster risk reduction will also ensure that we make the most of traditional best practices and indigenous knowledge."

This training is designed as an add-on six-day (48 hours) program to existing mason training programs. The training through its various learning sessions covers housing typologies, hazard occurrence and impacts, principles of hazard resistant construction, importance of site and soil conditions, specific safety features for foundation, plinth, walls, and roof. The training Methods involves theoretical sessions as well as hands on practice. This is a generic module and can be adapted to local and regional construction typologies. It is expected that on-going training programs under PMKVY, DDU-GKY, PMAY and others such schemes shall adopt this module to build local capacities for hazard resistant housing and minimising damage and loss due to natural hazards.



Kamal Kishore
Member, NDMA

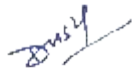

D.N. Sharma
Member, NDMA



Lt. Gen. N. C. Marwah
(Retd.)
Member, NDMA



R. K. Jain, IAS
(Retd.)
Member, NDMA

Acknowledgements

Preparation of training curriculum and trainers' manual for the masons to strengthen skills for hazard resistant construction is a complex task as there are diverse construction systems and different hazard profiles in different parts of the country. It is very challenging to develop a curriculum that would be useful for masons in all the regions. Learning from many past efforts and experiences for masons training have contributed in preparation of this training curriculum and trainers' manual.

Dr. V. Thirupugazh, Head of Policy and Planning Division, NDMA, has been instrumental in supporting and promoting this agenda of training masons on hazard resistant construction. The curriculum takes its clues from several documents available on the subject in public domain. One specific document needing special mention is the IITK-BMTPC 'Earthquake Tips' prepared by Prof. C.V.R. Murty, which provided the first base for this training curriculum.

UNNATI and People-in-Centre collaborated with NDMA to prepare this training curriculum and module. Shri Binoy Acharya and Shri Kirit Parmar of UNNATI provided technical guidance and support. Shri Vivek Rawal and Shri Rushank Mehta of People-in-Centre anchored the technical team to develop this curriculum and prepare the manual for trainers.

NDMA constituted technical expert committee under the chairpersonship of Prof. C.V.R. Murty for vetting this training curriculum and trainers' manual. We are thankful to the technical committee particularly Prof. C.V.R. Murty, Prof. R.K. Ingle, Dr. Alpa Sheth (VMS Consultants), Shri Amarjeet Sinha IAS (Secretary, Ministry of Rural Development), Dr. K. P. Krishnan IAS (Secretary, Ministry of Skill Development and Entrepreneurship) and Shri Binoy Acharya, who reviewed the curriculum and provided valuable inputs for finalization. We are also thankful to IIT, Kanpur and CEDAP, Ahmedabad for allowing use of their photographs for this Training Resource Material.

Preparation of this curriculum and trainers' manual is only a beginning of the greater effort that is now required to implement the training programs for skill building of masons on hazard resistant construction. It is hoped that this training curriculum will be widely used by various institutions, stakeholders and programs to build such capacities.

Background

In India, there is severe shortage of safe and adequate housing for its people. The housing situation is aggravated further due to large number of houses affected by natural disasters every year. Not only the loss of houses in terms of numbers, but also the conditions of existing housing stock are impacted due to natural disasters leading to deterioration in the quality of life of inhabitants. Every year, nearly 12 lakh houses are destroyed only due to floods. If one considers other hazards, like cyclone, earthquakes, landslides and tsunami, this number will go much higher. Also, it is necessary to point out that collapse of houses is one of the major reasons for loss of life in disasters.

Rural housing in India is largely an owner-led self-build process. Peoples' own savings and borrowings, in addition to the government assistance, form major part of housing finance, and real investment in rural housing is huge. NSSO 2004 indicated that the rural poor are continually engaged in construction activity. Usually, they construct their houses incrementally over a period of time as per their savings and requirements. Recently, for the flagship programme of rural housing - Pradhan Mantri Awas Yojana - Gramin, Government of India has proposed an outlay of INR 81,975 Crores to support construction of 1 Crore houses during the period 2016-17 to 2018-19 to meet this housing shortage and fulfil the growing demand. Hence, the loss of houses due to disasters can have significant impact on socio-economic well-being of the poor. With this background, building hazard resistant houses becomes very essential.

Well trained skilled human resources are extremely important for ensuring construction of hazard resistant houses. Most of rural housing activity is non-engineered and is primarily guided by the rural artisans. Masons play critical role in advising, guiding, managing and constructing houses. Over many decades in the past, significant loss has been seen of natural resources, building materials in particular, accessible to local communities, changes in occupational trends and increasing lack of affordability. Many of these factors have contributed to loss of traditional skills and knowledge of construction. While skills of traditional systems of construction have been diluted, knowledge of new modern systems of construction has not been fully reached the rural areas and this has resulted in very poor rural housing stock in past few decades.

This masons' training module for hazard resistant construction was a long felt need. NDMA has taken initiative to strengthen the rural artisans with the required skills. This training curriculum is prepared keeping in mind the diversity of construction techniques in the country, spatial-functional requirements of different regions and range of materials available and accessible to build houses. It focuses on principles and features of hazard resistant houses, specifically built through self-help or with help of petty contractors.

1. Introduction

Training Objective

The objective of this training curriculum is to strengthen the practising masons on hazard resistant construction techniques and features through theoretical and practical sessions. This training will make them aware not only of the critical principles of hazard resistant construction, but also provide some practical skills in appropriate and relevant details of rural housing technologies that people use in different regions of India.

This training is meant to guide masons on construction of non-engineered houses (up to two storeys) and does not cover construction of engineered buildings with Reinforced Concrete (RC) frame or multi-storey buildings.

Training Methods

This training module is envisaged to be for 48 hours spread over 6 days. Each training day is designed such that there is ample time for hands-on training of masons. The classroom sessions are planned using participatory methods with discussions, audio-visual presentations, models, etc. These sessions provide enough time and scope for the trainees to discuss their concerns, questions and issues. The practical construction sessions are to get hands-on experience of hazard resistant features and details used in construction work.

A maximum of 25 masons should be trained at one time with 3 resource persons training them.

Training Sessions

The training comprises of 18 sessions, consisting of 12 theory classroom and 6 practical sessions. These sessions are to be conducted in 48 hours over six days, with 19 hours in classroom, 25 hours in field and 4 hours of recapitulating sessions as well as test. The sessions are named in sequence of 1 to 18 and the prefix letter indicates the nature of session i.e. 'C' for classroom session and 'P' for practical exercises.

Session C1 is introductory classroom session, where participants will start interacting with each other and with the trainers. Their expectations from this training programme will be defined in this session. The participants will be encouraged to discuss the role the artisan play in influencing the choices of the house owners and promoting hazard resistance, specifically in context of self-built houses.

Session C2 introduces the participants to various building typologies constructed in the country. It focuses on regional context of the trainees. It will establish linkages between the building typologies and materials available as well as construction skills in the region. The session will lead to discussion on important role artisans have played in evolving these typologies.

Session C3 discusses different natural hazards and focuses on the locally experienced hazards, their severity, frequency and their impact on buildings. The natural hazards covered under different topics are earthquake, flood, cyclone, tsunami and landslide. There is flexibility to include other local hazards that may affect the particular region. The session gives conceptual understanding of different hazard zones that the

country is divided into and the impact a particular region would have vis-à-vis certain hazards. A specific discussion is initiated in the session on multiple hazards striking a particular region. Further, impact of the above hazards on buildings is discussed. Since buildings are subjected to gravitational force, they are meant to resist the vertical loads. But most natural hazards induce forces that are horizontal, for which too the buildings need to be designed for. These additional forces arising in each of the natural hazards, their nature and impact of them on buildings are discussed.

Session P4 is a practical session which is meant to instil the importance of good quality materials and workmanship in construction. Simple steps, rules and techniques are expected to be performed by participants to know their understanding of basics of construction. The session will help the trainers to know the skill levels of the participants so as to customise future instructions.

Session C5 is a classroom session focusing on the principles of hazard resistant construction. While discussing various hazards that induce damage, this session identifies the characteristics that help buildings survive these forces. Basic structural principles are discussed in this session with simple and often day-to-day life examples.

Session C6 discusses house size and shape and damage due to hazards. It talks about size, shape, scale and proportions of building and its elements that play important role in determining whether or not the building is prone to damage during hazards.

Session C7 is a classroom session discussing importance of building site and how different soil types impact hazard resistance of the house. Specific soil conditions, like house on black cotton or sandy soils, as well as special incidents, like liquefaction, are discussed in this session.

Session C8 discusses importance of selecting right type of foundation and plinth for specific conditions, which may help in hazard resistance. Specific cases of foundation for hilly terrain and landslide prone regions are discussed in this session.

Session P9 is meant to apply the theoretical knowledge gained in earlier classroom sessions in the construction exercises. Here, participants work in groups to construct foundations incorporating hazard resistant features. The foundations chosen in these exercises will be selected from the locally practised typologies. Also, participants will be exposed to basics of Reinforced Concrete (RC) footings and details of horizontal bands.

Session C10 is a classroom session focuses on hazard resistant features in walls. This session discusses the hazard resistance at two levels, in principle and in details of construction. It includes norms for openings, like doors and windows, for better hazard resistance.

Session P11 is a practical session to through construction of different types of walls incorporating hazard resistant features. The selection of these wall types will be based on the construction materials and techniques prevalent in the region. The necessary details of bands, corners and junctions, openings, etc., are to be incorporated in such construction.

In Session C12, the participants are introduced to concepts of hazard resistance in roofs. Roof construction and hazard resistant features in

different roof types are discussed based on shape and materials used. The principles and details of construction are discussed for both, sloped and flat RC roofs.

Session P13 is a practical session focusing on incorporating hazard resistant features in roof construction. It is envisaged that the masons may not necessarily carry out roof construction in case of timber roofs, but may more actively participate, if it is a RC roof. The session discusses plank and joist roof construction as may be prevalent in many regions.

Session P14 is a field visit session, in which the participants are taken to a pre-identified pre-existing house and an under-construction house near the training site. The participants will make observations on hazard resistant features already incorporated or the ones that need to be incorporated in existing situation to make the house safer. Further, part of the visit will be utilised to meet a material supplier, and identify different qualities of materials used in construction.

Session C15, a classroom session, is meant to introduce participants to various other house elements, where hazard resistant features need to be incorporated. These elements are staircases, parapets, balconies, *chhajjas*, verandahs etc. Vulnerability due to furniture and service installations is also discussed and necessary steps are evolved by a participatory method.

Classroom session C16 introduces participants to understanding the implications of hazard resistant features on cost of construction through comparative cost estimation. Here, it is stressed that safety is a choice that the owner and mason make along with aesthetic choices. In case of budget constraints, often, safety is compromised over specific choice of elements and materials. Such questioning, it is hoped, will help and guide the participants to make correct choices when restrained by limited budget or other such limitation.

Classroom session C17 is meant for clarifying any new questions or unanswered questions on hazard resistant construction, that participants may have. This gives opportunity to discuss the test questions and understand correct answers.

The training culminates with concluding Session C18, in which feedback of the trainees is sought on the trainings and trainers. Trainers' feedback on the entire group of participants is sought in this session. Further, any unanswered questions from participants are be clarified in this session. To conclude the training, mason's handbook and participation certificate are distributed.

Training Venue and Logistics

The training venue should have following spaces, equipment and facilities.

1. Classroom for 25 participants to sit comfortably with extra space for practical experiments and demos.
2. A large blank wall/screen for presentations, electrical connection for projector.
3. Black/ whiteboard and chalk/pens, chart papers, etc.
4. Outdoor space for hands-on practice of the construction details by the masons.

5. Additional facilities of drinking water, tea/lunch, and toilets.
6. Multimedia projector with speakers, computer, table, chairs or other arrangement for operating presentations.
7. Basic construction tools - trowel, hammer, plumb bob, level tube, measuring tape, pans for mixing mortar, bucket, notepads and pens for construction exercises in groups of two to four participants.

Eligibility of Trainees

A mason with minimum 2 years of practical experience in construction of rural houses. These masons should know basics of masonry, including masonry bonds, making mortar and line out.

Language of Training

Training structure and main topics are given in English. But, it is preferred that training is imparted in local language.

Trainer Team and Minimum Qualifications:

The trainer team is proposed to be consisting of three persons. A lead trainer, an assistant trainer (engineer or architect) and an assistant trainer (master mason). Further, construction helpers may be required during the practical training sessions and test. The construction helpers (labour) (at least one helper per trainee group) should be present at the site during the practical sessions of the training. Expected minimum qualifications for the trainers team is shown below:

1. Lead Trainer

The lead trainer should be a civil engineer (Degree or Diploma holder) or an architect having minimum 7 years of experience in relevant construction and having good communication skills. The trainer should have undergone the Training of Trainers Programme (ToT) himself/herself.

2. Assistant Trainer

The assistant trainer should be a civil engineer (Degree or Diploma holder) or an architect having minimum 3 years' experience in relevant construction and having good communication skills. The trainer should have undergone the ToT programme himself/herself.

3. Assistant Trainer (Master Mason)

A master mason should have minimum 5 Years of experience in relevant construction and have good communication skills. The trainer mason should have undergone the ToT programme himself/herself.

2. Training Curriculum

C1 Purpose of the Training and Introduction of Participants

Duration: 1 Hour

Expected Outcomes

1. Introduction of participants and trainers to each other.
2. The participants interact with each other and open up for further training sessions.
3. Trainers understand participants' level of knowledge, skill and attitude and define scope of training.

Session Details

Methods and Tools

Introduction (Skillsets/ experience/ expertise of the participants)

1. Interactive game to know each other – name, village, field of work and kind of buildings they have made
2. Making them introduce the other participants including the skillsets of their fellow participants
3. Introduce the completed/ on-going work/ building the participants are proud of
4. Discuss why they think these are good and what skills they showcased in these buildings to set the context of the training program

Method: group interaction, open discussion guided by the trainers, presentation by participants on blackboard or chart papers

Training materials and aids:

Papers, means of putting the paper up on the walls (tack board and pins), pencils/pens and chart papers

Experience sharing on past hazards.

1. Knowing the current level of participants' understanding of hazards and disasters in the region
2. Experience sharing on past disasters – recalling the event and its impact (how and who)
3. Discuss the importance of making buildings hazard resistant

Methods: participative discussion, experience sharing by participants

Training materials and aids:

Papers, means of putting the paper up on the walls (tack board and pins), pencils/pens and chart papers

Expectations from the training and defining the scope

1. Listing what participants expect to learn towards making buildings hazard resistant
2. Introduction to the structure of the training, i.e. 13 classroom and 4 practical sessions and the test/ evaluation method

Methods: Participative discussion to know expectations. (Suggested method: Distribute paper to each trainee to write expectations, read them to the group and put on tag

<p>going to be adapted, etc., to explain what and how they will learn about hazard resistant construction</p>	<p>board. Explain to what extent these expectations will be fulfilled.) Presentation by trainers (PPT1)</p> <p>Training materials and aids: Papers, means of putting the paper up on the walls (tag board and pins), pencils/pens and flipchart and pens` Projector, computer, screen and power supply</p>
---	---

C2 Housing Typologies of India and Role of Artisans

Duration : 1 Hour

Expected Outcomes

1. The participants understand relevant variety of housing typologies (traditional and conventional) in the region.
2. The participants know different materials, construction systems and contemplate on the relevance of the choice of materials to make hazard resistant houses.
3. Participants understand role artisans played by using available materials and help evolve the typologies in the region and its importance in hazard resistance.

Session Details	Methods and Tools
<p>Houses people build in the region</p> <ol style="list-style-type: none"> 1. Apart from own houses and houses they have built, preparing list of materials used in other houses the participants have usually observed. 2. How strong they think these houses are, against possible hazards in the region? 3. Is diversity in typologies good or bad? 4. It is possible to make all typology houses safe? 	<p>Method: Presentation by trainers (PPT2), Participative discussion moderated by trainers, listing, experience sharing by participants</p> <p>Training materials and aids: blackboard and chalks, flipcharts and pens</p>
<p>Types of houses in the region – role artisans played</p> <ol style="list-style-type: none"> 1. Traditional and conventional ways of building 2. Relationship between a particular building type and the impact of prevalent hazard 3. Role artisans played as advisor, designer and in execution of building 4. Choice of material, type of structure, skills and cost 5. Why one finds specific types of houses in some regions? Focusing on examples of same materials and regional variation, as well as similar hazards but different materials, etc., leading to understand the accessibility of materials, availability of skills, cost effectiveness, speed and quality of construction 	<p>Method: Presentation by trainers (PPT2), Participative discussion, experience sharing by participants</p> <p>Training materials and aids: Projector, computer, screen, power supply, blackboard and chalks, flipcharts and pens</p>

<p>Establishing the importance of resilient construction</p> <ol style="list-style-type: none">1. Risk that poorly designed / executed houses pose to human life and property2. Necessity of a stronger house to prevent this loss and maintain resilience to disasters3. Discussion on material, construction quality and resilience	<p>Method: Participative discussion moderated by trainers</p> <p>Training materials and aids: Blackboard and chalks, flipcharts and pens</p>
--	--

C3 Hazards : Their Severity, Zonation and Impact on Buildings

Duration: 1 Hour and 30 Minutes

Expected Outcomes

1. Knowledge of different hazards, their occurrences and frequency in the region.
2. Knowledge about severity of disasters and methods of measuring their intensity.
3. Participants locate their own region and understand different zones of disasters.
4. Participants understand the forces acting on buildings normally and during different hazards.
5. Participants understand damage to houses due to these forces.

Session Details

Significant past disasters in the country

1. Earthquake: tectonic plates and their movement, epicentre and hypocentre, and brief history of earthquake in India (Bihar, Shillong/ Assam, Kutch)
2. Floods: Types of floods (flash floods, slow fluvial floods and pluvial floods) and causes (rains, heat, dam breach, etc.). Flood examples – slow rising floods of flood plains (Assam, Bihar, etc.), dam breach (Nepal 2008 causing Bihar floods) and flash floods due to rain and drainage problems (Gujarat floods of 2008/2009/2015, etc.).
Obstruction to natural drainage and floods
3. Cyclones: Factors causing cyclones – atmospheric pressure difference and movement of air (Examples – Orissa, Kutch, Chennai) and establish relation of cyclones and storm surges
4. Landslides: Landslide and its causes, limited impact in mountain and hilly areas, specific to Himalayan region/ states (Uttarakhand, Sikkim)

Methods and Tools

Method: Presentation by trainers (PPT3a) with participative discussion and aided by local examples as well as linked videos

Training materials and aids: Projector, computer, screen, power supply, blackboard and chalks, flipcharts and pens

Associated hazard events : Possibility, examples and multiplication of impact

1. Earthquakes and floods (can dam breach due to earthquake?)
2. Earthquake and tsunami
3. Earthquake and fire

Method: Presentation by the trainers (PPT3a) with participative discussion

Training materials and aids: Projector, Screen, power

<p>4. Cyclone and floods</p>	<p>supply, blackboard and chalks, flipcharts and pens</p>
<p>Severity of disaster and units of measurement, hazard maps</p> <ol style="list-style-type: none"> 1. Earthquake: what the magnitude numbers may mean, how many times magnitude increases with each consecutive number on the Richter Scale 2. Floods: Rain Gauge, Importance of measuring how much water rises in how much time 3. Cyclone: What does it mean to have a wind speed of 100km/hr or 150km/hr ? Anemometer and simple method of measuring wind speed 4. Tsunami: To what extent can the water come inland, and height of the wave? 5. Landslide: What area or volume of land could slide, how does it impact buildings? 	<p>Method: Presentation by the trainers (PPT3a) with participative discussion</p> <p>Training materials and aids: Projector, computer, screen, power supply, blackboard and chalks</p>
<p>Normal Condition: Self-weight of building and gravitational force always present. Load transfer from roof to the ground using simple load paths. Hazards and the change in loading on buildings.</p>	<p>Method: Presentation by trainers (PPT3b) explaining forces on buildings. Additionally, explaining the forces using simple everyday examples about forces and damages, etc., followed by participatory discussion and analysis of pictures of damages to the buildings in past events of different disasters</p> <p>Training materials and aids: Projector, computer, screen, power supply, blackboard and chalks, flipcharts and pens</p>
<p>Earthquake</p> <ol style="list-style-type: none"> 1. Understanding Inertia and the dynamic loads 2. Loads in two main directions, parallel and perpendicular to the plain of wall 3. Understanding bending, shear, toppling and twisting 4. Understanding liquefaction 5. Damages due to earthquake forces <p>Flood</p> <ol style="list-style-type: none"> 1. Types of floods – coastal floods, riverine floods and surface floods 2. Riverine floods – flash floods and overbanks floods 3. Impact of water : thrust, submergence, erosion, capillary action 4. Scouring of soil and exposed foundation 5. Uplifting force on building during submergence 6. Loss of strength of certain materials due to moisture 	

7. Damages to buildings in different flood situations

Cyclone and heavy wind

1. Wind loads – horizontal forces
2. Uplifting, differential pressure and suction
3. Damages to buildings due to cyclone and wind

Landslide

1. High Impact force on localised scale
2. Loose ground and foundation shifting
3. Damages to buildings due to landslide

P4 Quality of Materials and Importance of Tools

Duration: 4 Hours 30 minutes

Expected Outcomes

1. Participants understand the importance of good quality materials.
2. Participants develop knowledge about construction tools and appropriate ways of handling them.
3. Trainers evaluate the existing knowledge of the participants in using different tools.

Assignments and Method

Training Materials and Aids

Groups: Make groups of two participants each. Each group will carry out three assignments. This will expose the participants to basics of good construction as well as help the trainers understand present skill levels of the trainees. End the session with observations and discussion on the samples made.

Exercises:

1. Quality standards for construction materials (1 hour 30 minutes)

The different field tests suggested are:

- a. For Brick: Sound test, drop test, shape, size, edge and colour observations
- b. For Stone: different shapes, size, edge, surface (flaky or smooth)
- c. For sand: Well graded (particle size), salt content, impurities
- d. For concrete blocks: size, shape, quality of edges, texture, drop test
- e. For wood: Section size, straightness, knots, soft and hard, identifying species, colour, texture, grains, smell, borer holes
- f. For bamboo: Wall thickness, taper, diameter, knot distance, maturity, species of bamboo, borer holes
- g. For cement: ISI mark on bag, grade of cement, moisture
- h. For steel: ISI mark, TOR steel (rerolled or not), corrosion, diameter

Measuring tapes, water, 3 different quality samples of each material – brick, stone, sand, concrete blocks (hollow and solid), wood, bamboo, cement, reinforcement bars

Preparation: Charts to record their findings about quality of materials

2. Understanding use of tools in plan line out and construction (2 hour)

- a. Using right-angle rule of 3-4-5 and L angle

Pegs, strings, hammers, measuring tapes for each group

<ul style="list-style-type: none"> b. Use of sting and measuring tape c. Use of measuring box d. Use of pegs and markers e. Use of water-level and spirit level f. Use of plumb-bob 	<p>Preparation: Simple layout map for the groups</p>
<p>Trainers should observe and encourage participants to use construction tools like, spirit level, plumb bob, thread, and levelling tube</p>	<p>Measuring tape, pegs, hammers, spirit levels, L angle, plumb bob, thread, measuring box, levelling tube, trowel for each group</p>
<p>Gather the participants for discussion (1 hour)</p> <ol style="list-style-type: none"> 1. Importance of ensuring the use of good quality materials for hazard resistant construction 2. Role of quality control in workmanship – badly constructed building with very expensive materials vs. well-constructed building 3. Importance of using the right tools to ensure good quality 	

C5 Principles of Hazard Resistant Construction

Duration : 1 Hour

Expected Outcomes

1. To develop understanding on hazard resistant construction technologies and materials to reduce risk and minimise loss of life.
2. Contextualising – the vulnerability in local construction.

Session Details	Methods and Tools
<p>Forces applied to the buildings during hazards</p> <ol style="list-style-type: none"> 1. Earthquake: Inertia, shaking, twisting 2. Flood: Thrust force, erosion, submergence 3. Cyclone: Uplifting, suction, pressure 4. Landslide: Impact, sliding/ loose base 	<p>Method: Listing by participants with guidance from trainers</p> <p>Training materials and aids: blackboard and chalk, flipcharts and pens</p>
<p>Identifying principles that help the house survive these forces</p> <p>A. Structural Robustness</p> <ol style="list-style-type: none"> 1. Importance of robustness 2. Design principles <p>B. Integrity</p> <ol style="list-style-type: none"> 1. Integrity of building and tying of different building elements 2. Why a complete box is more stable and hence desirable? 3. Joinery and details between plinth to walls, walls to roof and different roof elements 4. Ensuring roof (tiles and sheet materials) is properly secured against different hazards <p>C. Elasticity</p> <ol style="list-style-type: none"> 1. Where and when to use elastic materials in building. <p>D. Ductility</p> <ol style="list-style-type: none"> 1. Concepts of Brittleness, rigidity and ductility. 2. Introduction of reinforcement for ductility. 3. Use of vertical RF bars and horizontal bands in masonry structures <p>E. In-plane deformation and Cross/ knee bracing</p> <ol style="list-style-type: none"> 1. How bracing resists in-plane deformation 2. Strengthening of wooden/bamboo structures by adding cross bracing. 	<p>Method: Presentation by trainers (PPT5). Additionally, explaining the content by simple examples from everyday life about forces and damages, etc., followed by observations by participants</p> <p>Training materials and aids: Projector, Screen, power supply, blackboard and chalks, flipcharts and pens</p>

<p>E. Protection from water and wind:</p> <ol style="list-style-type: none"> 1. Plinth height, plinth protection, roof projections and other means of water resistance 	
<p>Discussing local housing typologies in context of different hazards</p> <ol style="list-style-type: none"> 1. Discussion on how these hazard resistant principles are incorporated in their local typologies 2. Identifying vulnerabilities - are they adequate? 	<p>Method: Observations by participants and moderated discussion</p> <p>Training materials and aids: Blackboard and chinks, flipcharts and pens</p>

C6 Hazards Resistant features for House Size and Configuration

Duration : 1 Hour

Expected Outcomes

1. Masons develop an understanding of the optimal sizes, configurations and building mass of the house and their risk resistance performance to hazards.

Session Details

Building design concepts

1. Size and proportions of buildings - length, height, depth, (optimal dimensions: too tall, too wide, too large)
2. Setbacks and asymmetry (asymmetry in plan and torsion, asymmetry in elevation)
3. Adjacency of buildings
4. Shapes of buildings: Simple and complex shapes, like square, curved and corners
5. Differing storey heights
6. Short columns
7. Discontinuation of structural elements, like stub columns

Understanding risk resistance performance of building plans and features to hazards

1. Breaking complex shapes into simpler configurations
2. Layout of group of buildings to reduce tunnelling effect

Methods and Tools

Method: Presentation by trainers (PPT6). Additionally, explaining the content by simple examples from everyday life followed by observations by participants

Training materials and aids: Projector, screen, power supply, blackboard and chalks, flipcharts and pens

C7 Importance of Site and Soil Conditions

Duration: 1 Hour

Expected Outcomes

1. Participants know importance of better location and need for desirable site features.
2. They learn to modify site conditions where possible, to make it safer.
3. They understand soil types and its impact on foundation – stability of houses.

Session Details

Methods and Tools

How settlements develop

A discussion with example of the villages in the region and how these sites may have been selected, grown and current situations with regards to vulnerable areas/ low-lying settlements.

Method: Participative discussion guided by trainers

Training materials and aids: blackboard and chalks, flipcharts and pens

Importance of site features with regards to different hazards

1. Annual average floods and location of building
2. Natural features acting as barriers for floods or Tsunami
3. Wind breakers or barriers around the site for cyclone resistance
4. Trees, boundary walls, etc.
5. Location of building in landslide prone sites

Method: Presentation by trainers (PPT7). Additionally, explaining the content by simple examples from everyday life followed by observations by participants

Training materials and aids: Projector, computer, screen and power supply blackboard and chalks, flipcharts and pens

Understanding the soil composition and its relevance in construction

Settling, sliding and liquefaction of soils and their impact on buildings

Measures that may be taken to build on difficult soil and site conditions:

1. Low bearing capacity
2. High water table
3. Expansive and Clayey soil
4. Highly sloped terrain

C8 Hazard Resistant Features for Foundation and Plinth

Duration: 1 Hour

Expected Outcomes

1. Participants understand importance of foundations in hazard resistant construction.
2. They are able to select appropriate foundation for local conditions.

Session Details

Methods and Tools

Revisiting different types of foundations and plinths built in the region (materials and construction technique)

Typical Damage to Foundations and Plinths

1. Uneven settlement of soil and impact on foundation
2. Uneven foundation depth and building settlement
3. Scouring of foundation and wall base in strip foundation

Method: Participant discussion, listing of different foundation construction methods and damages

Training materials and aids: Blackboard and chinks, flipcharts and pens

Choosing the right type of foundation for house

Principles and Details

1. Strip foundations- Stone, brick
2. Stub Foundation
3. Anchoring Vertical reinforcement
4. Bonding L and T junctions
5. Filling mortar and sand properly
6. Through stones in stone foundations(Alternatives for through stones)
7. Reinforcement bars in an RCC Footing.
8. Plinth height, plinth protection and damp proofing
9. Grade beam, Plinth band: Different materials that can be used to make them.

Method: Presentation by trainers (PPT8) and simple examples based on observations by participants

Training materials and aids: Projector, screen, power supply, blackboard and chinks, flipcharts and pens

Hilly Terrain and Foundations in Landslide Prone Regions

P9 Constructing Sample Foundation and Plinth

Duration: 3 Hours 30 Minutes

Expected Outcomes

1. Participants understand critical concepts of siting and details of construction of foundation and plinths.
2. They make observations on the site for hazard resistant construction.
3. They are able to construct good details for hazard resistant foundation and plinths.

Assignments

Training Materials and Aids

Group: Make groups of 2 participants each. Each group will construct one of the following foundations. They can build the foundation as per their skillset of approximately 1.2m length incorporating the elements for strengthening foundation and plinth (like grade beam, plinth band or vertical reinforcement wherever applicable). Each group shall be provided one helper to assist them with the construction. End the session with observations and discussions on the samples constructed.

Exercise: Each group should construct one of these foundations (or more depending on local practices), incorporating the details for vertical reinforcement (where applicable), grade beam and plinth band (use of RCC, timber, bamboo or other materials for the bands) and understanding the damp proofing.
(2 Hours 30 Mins.)

1. Strip Foundation in Stone

Main points: Compacting the soil, continuous and corner bonding, through stones, sand filling, settling with water, anchoring vertical reinforcement, different ways of filling the joints with mortar or sand properly, through-stones options (stagger at least $\frac{3}{4}$, can u cast RCC as through stones?)

2. Strip Foundation in Brick

Main points: construct two courses of each width must be made 2 $\frac{1}{2}$, 2, 1 $\frac{1}{2}$ and 1 brick to make L and T shaped stepped foundation. Corners, anchoring reinforcement bars, filling joints properly.

3. Stub Foundation in Brick

Main points: construct stub foundation of 2 $\frac{1}{2}$ x 2 $\frac{1}{2}$ bricks, until it reaches the top at 1

Measuring tape, spirit level, L angle, plumb bob, thread, measuring box, levelling tube, trowel. Stones, bricks, dry mortar, wire mesh, plastic sheet, plumb bob, different types of trowels, digging tools, crowbar, bucket to mix mortar (ghamela), reinforcement bars, gravel, bending wire and any other materials required for construction.

Preparation: Timber ladder, bamboo ladder and steel cage for RCC grade beam and plinth band may be kept ready for using as bands.

<p>½ x 1 ½ brick stub with a vertical reinforcement bar in the centre.</p> <p>Discussion about Practical classes: Positives, mistakes, and how things could have been done better. So each type of foundation is discussed with entire group.</p>	
<p>The participants may gather to understand simple RCC footing and the steel cage and casting details of footing. (1 Hour)</p> <p>The details of bands and beam along with footing and vertical reinforcement must be discussed, such that participants are aware of the requirements from the wire benders, carpenters and bamboo artisans they work with.</p>	<p>Preparation: Half cast ready samples of RCC footing cage for RCC foundation for discussion. Half cast samples of RCC grade beam, horizontal RCC bands along with timber ladder and bamboo ladder used in previous session need to be explained.</p>

C10 Hazard Resistant Features of Walls and Openings

Duration: 3 Hours

Expected Outcomes

1. Participants are aware of various damages inflicted upon load bearing and in-fill walls during different hazards.
2. They know construction methods of mitigating impact of hazards on walls (principles and design limits).
3. They are aware of safety features and measures for increasing resilience of walls during hazards through construction details (masonry bonds, corner junctions, vertical reinforcements, etc.).

Session Details

Revisiting different types of walls built in the region (materials and construction technique)

Typical Damages to Walls

1. Vertical separation at the corners
2. Diagonal cracks from top to bottom and near openings
3. Crushing of masonry units/ disintegration of wall
4. Delamination of inner and outer surfaces

Load bearing masonry: Brick, stone, CSEB and concrete block

1. Principles

Wall density, wall thickness, wall height and proportions

2. Box action in masonry construction
3. Connecting adjacent walls

Details

1. Masonry Bonds – importance of staggering joints, through stones, avoiding vertical joints, corner details. (English, Flemish)
2. Horizontal bands and their importance, difference between a band and a beam.
3. Corner and jamb Strengthening (vertical reinforcement and wall junctions)
4. Construction of corner masonry first, middle part later
5. Gable wall – use of lighter materials / gable band

Methods and Tools

Method:

Listing by participants with help from trainers.
Explanation by the trainers.
Presentation by the trainers (PPT10) with participative discussion and simple examples based on observations by participants

Training materials and aids:

Projector, computer, screen, and power supply
Blackboard and chalks, flipcharts and pens

<p>Confined Masonry – Principles and Construction</p> <ol style="list-style-type: none"> 1. Horizontal and vertical RC elements 2. Masonry panels 3. Wall masonry first, corner elements later RC elements and wall masonry joinery <p>Limitations of Load Bearing Non-masonry Walls</p> <ol style="list-style-type: none"> 1. Cob, rammed earth and other types of walls 	
<p>Openings in load bearing walls</p> <ol style="list-style-type: none"> 1. Distance from corners, securing the openings and provision of jambs, lintel (isolated and continuous band) 	

P11 Constructing Hazard Resistant Walls

Duration: 4 Hours 30 Minutes

Expected Outcomes

1. Participants understand and can implement critical details and methods of wall construction.

Assignments

Training Materials and Aids

Group: Participants should form groups of two. Each group should be provided one helper to assist them in construction. Each group will construct a different load bearing wall of 'C' or 'Z' shape with the main flank of 4 feet height and 6 feet length approximately.

Following wall types are suggested:

1. Brick Masonry with English/Flemish bond.
2. Brick Masonry with Rat Trap Bond
3. Coursed random rubble Stone Masonry
4. Confined Masonry with bricks
5. Block Masonry (compressed earth block, concrete hollow block, concrete solid block)

Locally prevalent other wall types are encouraged to be taken up by relevant mason groups. In case of more groups, some of these wall types may be repeated.

Each group must construct the wall including the following features:

1. 1 Horizontal band
2. 1 L or T junction with corner reinforcement or other appropriate detail
3. 1 detail for jamb of an opening
4. Use of through stones (in Stone masonry)

Measuring tape, spirit level, L angle, plumb bob, thread, measuring box, levelling tube, trowel. Stones, bricks, CSEB/ concrete blocks, wire mesh, plastic sheet, plumb bob, different types of trowels, digging tools, crowbar, bucket to mix mortar (ghamela), reinforcement bars, gravel, bending wire.

C12 Hazard Resistant Features of Roofs and Ceilings

Duration: 3 Hours

Expected Outcomes

1. Participants know about various roof types observed in the region – sloping, flat roofs and other types.
2. They are able to analyse the problems and weaknesses in roofs that result in damages to the buildings and learn how to mitigate them.

Session Details	Methods and Tools
<p>Roofs in the Region: Materials and Construction</p> <ol style="list-style-type: none"> 1. Sloping Roof systems: ridge-rafter-purlin system and truss system. 2. Flat Roof systems: Discuss plank-joint roof and RCC slabs. 3. Other local roof systems prevalent in the region should be taken up <p>Typical damages to the roof</p> <ol style="list-style-type: none"> 1. Uplifting of roof from edges (during cyclones) 2. Light roof and heavy roofs(during earthquakes) 3. Gable wall damage due to hammer effect of ridge beam <p>Pros and cons of different systems in different hazards</p>	<p>Method: Listing by participants with help from trainers. Explanation by the trainers. Presentation by the trainers (PPT12) with participative discussion.</p> <p>Training materials and aids: Projector, computer, screen, power supply Blackboard and chalks, flipcharts and pens</p>
<p>Principles of Hazard Resistant Roof Construction</p> <ol style="list-style-type: none"> 1. Diaphragm action and in-plane bracings/ RCC slab 2. Box Action 3. Basic concepts of spanning (one way and two way slabs) and reinforcement requirements for RCC slabs <p>Details</p> <ol style="list-style-type: none"> 1. Roof-Wall Junction and wall plates 2. In-plane bracing for sloping roof 3. Fixing of ridge beams, rafter and purlin 4. Fixing of roofing tiles or sheets. 5. Design and Securing Overhangs and eaves. 	<p>Method: Presentation by trainers (PPT12) and simple examples based on observations by participants</p> <p>Training materials and aids: Projector, computer, screen and power supply Blackboard and chalks. flipcharts and pens</p>

P13 Constructing Hazard Resistant Roofs and Ceilings

Duration: 4 Hours 30 Minutes

Expected Outcomes

1. Through practical implementation, participants understand critical details and methods of roof construction

Assignments

Training Materials and Aids

Group: Participants will be divided into groups of two. They will build the plank and joist roof and RCC roof details followed by discussion on the samples constructed by the groups.

Further, there will be demonstration/ discussion on filler slab, gable and hipped roofs through full scale demos or scaled models.

Flat Roofs

1. Construction Exercise
Plank and Joist: on two parallel walls. The participants will construct a stone plank and joist roof.
Assembling of reinforcement of RCC slab
2. Demonstration and discussion
RCC slab: reinforcement details for one way and two way slabs, edge beam reinforcement, column to roof steel detail at junction.

Measuring tape, spirit level, L angle, plumb bob, thread, measuring box, levelling tube, trowel, planks, joists, bricks, sand, wire mesh, plastic sheet, plumb bob, different types of trowels, digging tools, crowbar, bucket to mix mortar (ghamela), reinforcement bars, gravel, bending wire.

Preparation:

1. Keep at least 4 courses high masonry walls ready for constructing the plank and joist roof.
2. For demonstration and discussion purpose, steel reinforcement cage for RCC slab and filler slab should be kept ready.

Sloping Roof

Demonstration of design of truss system and design of ridge beam, rafters, purlins system. Different elements and joinery of roof to wall, wall plate, eaves detail, in-plane bracings etc.

Preparation: Keep models of gable and hipped roofs ready for discussion and demonstration purpose. One may be with sheet roof and the other with tiles, one with ridge beam and the other with truss system.

Points for Discussions

1. Roof and wall junction in flat and sloping roofs

<ol style="list-style-type: none">2. Tying of different roof elements through joinery3. Design of truss4. Joinery of vertical reinforcement, roof band and the slab in different conditions namely, : (i) vertical corner reinforcement bar, (ii) Vertical RC elements of confined masonry, and (iii) no vertical reinforcement	
---	--

P14 Field Visit: Rural House Construction and Materials Available

Duration: 8 Hours

Expected Outcomes

1. Participants can identify common construction problems pertaining to hazard resistance in their context and understand the application of hazard resistant features.
2. They develop knowledge about good quality materials available in the market.

Assignments

Training Materials and Aids

Group: the participants may go together to visit the houses/ village identified in advance and later to the material suppliers nearby, selling bricks, steel, cement, sand, blocks, etc. If there are any CSEB manufacturers in the region, a visit to the unit should be organised to understand the material and process.

Field visit to a nearby village to observe the houses in the region (completed and under construction) and learn the following.

1. Various house types people build
2. Common construction mistakes that lead to vulnerabilities
3. Ways to mitigate them applying the learning from the training, through discussion among participants and with house owners/ masons.
4. Observations leading to further details in region that may be incorporated or evolved to help disaster resilience in the region

An appropriate vehicle for the participants and trainers to visit the village.
Sketch pad/ diary, pencils/ pens and measuring tape for each group to record their observations and visualizations.

Preparation: The trainers should identify appropriate examples (a combination of completed, under construction IAY\PMAY houses) in a nearby rural settlement where the participants can observe the features of hazard resistant construction that have or have not been kept in mind while constructing the house.

Later, the participants visit nearby material suppliers and discuss the available materials and their quality. They also discuss the difference in rates of good and bad quality materials.

The trainer moderates the discussion and helps the participants to conclude their findings on the quality and recommendations for use.

Visit to material manufacturing unit and discussion with the manufacturer for CSEB/ Fly-ash other materials.

The trainers may identify conventional material suppliers and CSEB/ fly ash bricks/ other material manufacturing units (if there are any) near the field visit area.

C15 Hazard Resistant Features for Other Construction Elements

Duration: 2 Hours

Expected Outcomes

1. Participants know about aspects of hazard resistance in miscellaneous building elements.

Session Details

Methods and Tools

Impact of hazards on miscellaneous elements and ways to mitigate the impact

1. **Parapets:** lightweight and appropriate height for parapets for earthquake and flood as well as cyclones. Discuss parapets on cantilevered slabs.
2. **Balconies and chajjas:** introduction of brackets, lightweight construction. Limits for overhanging and steel design for hazard resistance. Use of RCC, stone etc. and appropriate anchoring.
3. **Staircases:** Separating the staircase from the main structure to avoid damage to main structure during earthquake shaking. Usefulness during floods. Importance of support and anchoring at base and landings.
4. **Verandah:** Columns must be properly braced in earthquake prone regions. It must be anchored properly to the roof and plinth of the building so that it does not get unhinged.
5. **Overhead tanks:** Explain the load it carries and the structural need to support heavy load. Common mistakes and damages, and ways to mitigate.

Method: Presentation by trainers (PPT15) and simple examples based on observations by participants on the practice they follow and if it needs modification.

Training materials and aids: Projector, Screen and power supply, blackboard and chalks, flipcharts and pens

Services and Furniture

1. Electricals: To avoid electrocution
2. Plumbing: To avoid leakage and disease. Soak pits (away from foundations and water source)
3. Internal layout and furniture (clutter free exit route, hanging objects, etc.)

C16 Estimation of Quantities and Costs

Duration: 1 Hour

Expected Outcomes

1. Participants are able to estimate cost of the house including hazard resistant features.

Session Details

1. Listing various elements of construction based on the house designs provided by the trainers with brick and stone walls and sloping and flat roof, using appropriate foundation. Based on local construction practices, more material options may be taken up.
2. Quantities of materials required for each of the building elements, like foundation, walls, bands, roofs, roofing materials, vertical reinforcements and openings
3. Rates of materials collected from local market and participants' and trainers' knowledge.
4. Cost estimation for each elements of the house and overall cost of the house in absolute and per sqm terms
5. Cost comparison with or without the hazard resistant materials in absolute and per sqm terms

Methods and Tools

Method: Presentation by trainers (PPT16) explaining the house plans for cost calculation

Finding and identifying various house elements, materials required, quantities of those materials, rates based on question-answers and consensus building through participative discussion

The information about quantities and cost to be filled in on given blank tables printed on sheets

Training materials and aids: Projector, computer, screen and power supply Blackboard and chinks, flipcharts and pens
Sheets containing tables (for house elements, materials, quantities, rates and cost) and pens/ pencils

Preparation: based on local materials, the given table TBL16 needs to be modified and enough sheets should be printed/ copies made to be distributed to participants for filling up.

C17 Clarification of Questions

Duration: 1 Hour

Expected Outcomes

1. Doubts and questions of the participants about any aspects of hazard resistant construction in the region are clarified including test questions.

Session Details

The trainer can ask again, if there has been any such situation which you face in regards to building hazard resistant homes, which hasn't been dealt with in the training program. Other participants would be encouraged to answer these questions, and if unanswered, trainers would clarify them.

The questions asked in the test should be clarified to the participants in the session.

Methods and Tools

Method: Questions by trainees first to be attempted by other trainees.
Unanswered questions to be clarified by trainers.

Training materials and aids: Blackboard and chalks, flipcharts and pens

C18 Concluding Session

Duration: 2 Hour

Expected Outcomes

1. Feedback for the trainer, trainees and the training session is collected.
2. Trainee manual is handed out and its use is explained.
3. Certificates are distributed.

Session Details

Methods and Tools

Training feedback: Looking back from the first day pin-up cards and assessing if the objectives and expectations of each person have been met.

Trainer Feedback: The trainers ask the trainees to share their experience, whether their expectations were met and also elaborate on the parts of the training that will help them in their future engagement in construction.

Trainee Feedback: Trainers talk about the response of the trainees. The part of the training the trainees responded well and part where the trainers' expectations were not met well and where the trainees can further improvise through training hand-out.

Method: Recollecting and reviewing the pin-up cards. Feedback and experience sharing by the trainees and trainers.

Distribution of Hand-out

Explanation of how masons may use it in their daily work

Method: Distribution of trainee's hand-out booklet and presentation by trainers (PPT18) explaining 'how to use' it.

Certificate Distribution

3. Training Schedule

Session	Topics	Duration
DAY – 1		
C1	Purpose of Training and Introduction of Participants	09.00 to 10.00
C2	Housing Typologies of the Region: Contribution and Role of Artisans	10.00 to 11.00
C3	Hazards: Severity, Zonation and Impact on Buildings	11.00 to 12.30
Lunch Break		
P4	Examining Quality of Materials and Importance of Construction Tools for Good Quality Construction	13.30 to 18.00
DAY – 2		
	Recapitulating the Previous Day's Learning	09.00 to 09.30
C5	Principles of Hazard Resistant Construction	09.30 to 10.30
C6	Hazard Resistant Features for House Size and Configuration	10.30 to 11.30
C7	Importance of Site and Soil Conditions	11.30 to 12.30
Lunch Break		
C8	Hazard Resistant Features : Foundation and Plinth	13.30 to 14.30
P9	Constructing Sample Foundation and Plinth	14.30 to 18.00
DAY – 3		
	Recapitulating the Previous Day's Learning	09.00 to 09.30
C10	Hazard Resistant Features : Walls and Openings	09.30 to 12.30
Lunch Break		
P11	Constructing Hazard Resistant Walls	13.30 to 18.00
DAY – 4		
	Recapitulating the Previous Day's Learning	09-00 to 09.30
C12	Hazard Resistant Reatures : Roofs	09.30 to 12.30
Lunch Break		
P13	Constructing Hazard Resistant Roofs	13.30 to 18.00
DAY – 5		
	Recapitulating the Previous Day's Learning	09-00 to 09.30
P14	Field Visit: Rural House Construction and Materials Available	09.30 to 12.30
Lunch Break		
P14	Field Visit (continued)	13.30 to 18.00
DAY – 6		
	Recapitulating the Previous Day's Learning	09.00 to 09.30
C15	Hazard Resistant Features for Other Construction Elements	09.30 to 11.30
C16	Estimation of Quantities and Costs	11.30 to 12.30
Lunch Break		
	Tests	13.30 to 15.30
C17	Clarification of Questions	15.30 to 16.30
C18	Concluding Session	16.30 to 18.00

4. Training Material

C1

Introduction

No. of Slides: 9
Time: 1 hour



National Disaster Management Authority



Unnati
Organisation for Development Education



People in Centre

Good morning!

Welcome to the beginning of
Building Safer Homes

Hello,

We are your training team for the next 6 days.



(Name)



(Name)



(Name)

Form groups of **2-3** people each!

Introduce yourself in the group by answering the following questions

Q1. What is *your name* and *which village* are you from?

Q2. What is the *kind of work* do you do: Brick masonry, stone masonry or any other? What is the best building you have worked on?

Q3. What are the *places you have visited* for work?

Q4. How many *years of experience* do you have: As a mason and as a Helper?

Q5. How did you learn *the skills* you have right now?

Have you experienced a Disaster?



Let's share our experiences by answering the following questions:

- 1. Have you experienced any natural disaster? List those disasters.**
- 2. Any other disaster you have not experienced, but know about?**

Have you
experienced a
Disaster?



3. For each hazard/ experience, let's ask the following:

- a) How long ago did it occur?
- b) Where were you when it occurred?
- c) What did you see around you?
- d) How severe was it? (What was happening? How high was the water/what was shaking/how fast was the wind blowing? How long did it last?)
- e) Do you know why it happened?
- f) What was the damage?
- g) How big was the region affected? Was the whole region equally affected?

How will this
program help
you?

1. Learning to **build safer homes**.
Over the next **6 days**, in 19 hours of theory and 25 hours of practical classes.
2. Each participant steps out with the knowledge and skills to build hazard resistant homes and contribute to saving lives and property.

Structure of the training

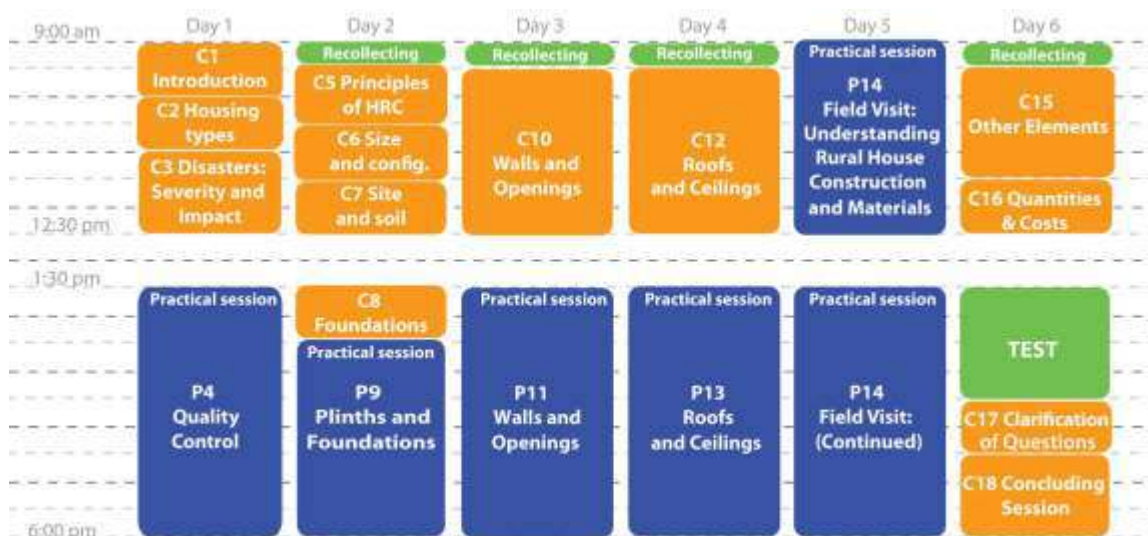

C2

Housing Typologies in India and Role of Artisans

No. of Slides: 25

Time: 1 hour



National Disaster Management Authority



Unnati

Organisation for Development Education



People in Centre

Expected Outcomes

1. The participants understand relevant variety of housing typologies in the region (traditional and conventional).
2. The participants know different materials, construction systems and contemplate on the relevance of the choice of materials to make hazard resistant houses.
3. Participants understand role artisans play by using available materials and help evolve the typologies in the region and its importance in adding hazard resistance to houses.

Prepare a list of materials used in houses you have built, lived or observed in the region.

1.

How strong you think these houses are, against possible hazards in the region?

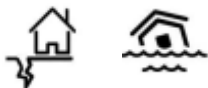

Earthquake Flood



Tsunami Landslide



Cyclone Fire

2.

Is diversity in materials good or bad?

Advantage: Building with many materials reduces stress on a single material, and controls cost.

- Stone
- Brick
- Mud
- Cement
- Wood
- Steel
- Other materials

3.

Is it possible to make houses using all these materials **safe during natural hazards?**

1. Construction with Cob Walls

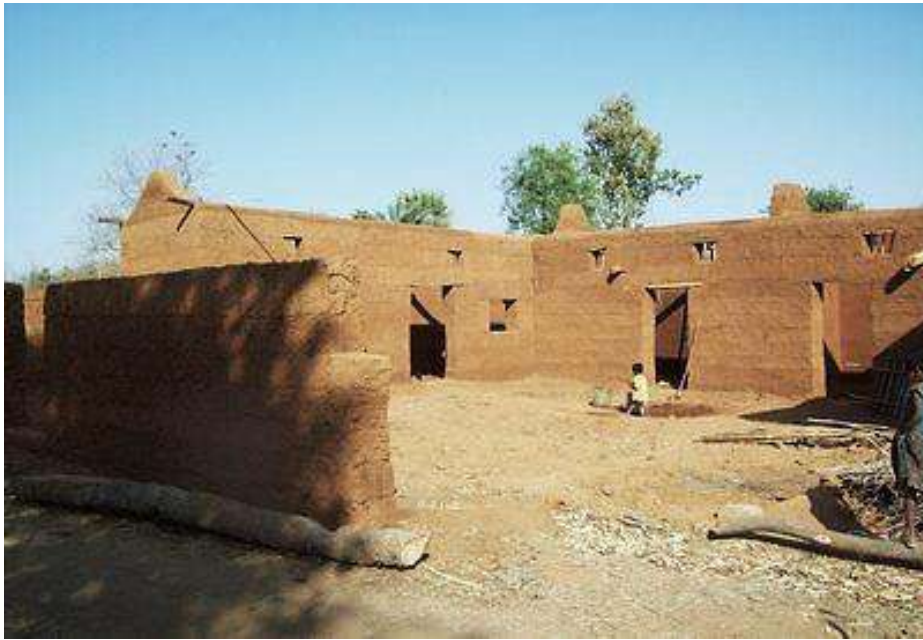

C2 Housing Typologies in India and Role of Artisans
NDMA Unnati PIC

4



Cob walls with timber and mud flat roof - **Haryana**



Cob walls with thatch gabled roof - **Madhya Pradesh**



Cob walls with thatch roof over circular plan - **Gujarat**



Cob walls with thatch hipped roof - **West Bengal**



Cob walls with tiled hipped roof - **Chhattisgarh**

C2 Housing Typologies in India and Role of Artisans
NDMA Unnati PIC

5

2. Construction with **Wattle and Daub Walls**



C2 Housing Typologies in India and Role of Artisans
NDMA Unnati PIC

6



Wattle and daub walls with sheet
hipped roof - **Kerala**



Wattle and daub walls with thatch
hipped roof - **Arunachal Pradesh**



Wattle and daub walls with
Mangalore tiles gabled roof - **Odisha**



Wattle and daub walls with
Mangalore tiles hipped roof -
Maharashtra



Wattle and daub walls with thatch
roof - **Nagaland**



Wattle and daub walls with thatch/
filed hipped roof - **Jharkhand**

C2 Housing Typologies in India and Role of Artisans
NDMA Unnati PIC

7

3. Construction with **Adobe Walls**



C2 Housing Typologies in India and Role of Artisans
NDMA Unnati PIC

8



Adobe walls with thatch hipped roof
- **Sikkim**



Adobe walls with timber & mud flat
roof - **Haryana**



Adobe walls with country tiles
gabled roof - **Rajasthan**



Adobe walls with thatch hipped roof
- **West Bengal**



Adobe walls with timber & mud flat
roof - **Himachal Pradesh**



Adobe walls with thatch gabled roof
- **Uttar Pradesh**

C2 Housing Typologies in India and Role of Artisans
NDMA Unnati PIC

9

4. Construction with Rubble Stone Walls



C2 Housing Typologies in India and Role of Artisans

NDMA

Unnati

PIC

10



Stone rubble masonry walls with CGI sheets gabled roof- **Jammu & Kashmir**



Stone rubble masonry walls with slate stone gabled roof- **Chhattisgarh**



Stone rubble masonry walls with CGI sheets gabled roof- **Himachal Pradesh**



Stone rubble masonry walls with thatch hipped roof- **Jharkhand**



Stone rubble masonry walls with mangalore tiles gabled roof- **Uttarakhand**



Stone rubble masonry walls with country tile flat roof- **Dadra and Nagar Haveli**

C2 Housing Typologies in India and Role of Artisans

NDMA

Unnati

PIC

11

5. Construction with **Ashlar Stone Walls**



C2 Housing Typologies in India and Role of Artisans
NDMA Unnati PIC

12



Ashlar Stone Walls with Mangalore tiles gabled roof- **Karnataka**



Ashlar Stone Walls with RCC flat roof- **Kerala**



Ashlar Stone Walls with country tiles hipped roof- **Chattisgarh**



Ashlar Stone Walls with Mangalore tiles hipped roof- **Goa**



Ashlar Stone Walls with CGI sheets hipped roof- **Himachal Pradesh**



Ashlar Stone Walls with shingle gable roof - **Jammu & Kashmir**

C2 Housing Typologies in India and Role of Artisans
NDMA Unnati PIC

13

6. Construction with **Timber Walls**



C2 Housing Typologies in India and Role of Artisans
NDMA Unnati PIC

14



Timber walls with timber gabled roof- **Uttarakhand**



Timber walls with thatch hipped roof- **Sikkim**



Timber walls with mangalore tiles hipped roof- **Kerala**



Timber walls with slate stone hipped roof- **Himachal Pradesh**



Timber walls with CGI sheets hipped roof- **Jammu & Kashmir**



Timber walls with CGI sheet hipped roof- **Sikkim**

C2 Housing Typologies in India and Role of Artisans
NDMA Unnati PIC

15

7. Construction with **Burnt Brick Walls**



C2 Housing Typologies in India and Role of Artisans
NDMA Unnati PIC

16



Burnt Brick walls with RCC flat roof- **Uttar Pradesh**



Burnt Brick walls with country tiles gabled roof- **West Bengal**



Burnt Brick walls with mangalore tiles gabled roof- **Tamil Nadu**

C2 Housing Typologies in India and Role of Artisans
NDMA Unnati PIC

17



Burnt Brick walls with RCC flat roof- **Haryana**



Burnt Brick walls with CGI sheets gabled roof- **Meghalaya**



Burnt Brick walls on cantilevered RCC flat roof- **Assam**



Burnt Brick walls on stilts with Thatch gabled roof- **Arunachal Pradesh**

C2 Housing Typologies in India and Role of Artisans

NDMA

Unnati

PIC

18

What is the relationship between:



Why one finds specific types of houses in some regions?
(Eg. Ease of access to materials and skills)

C2 Housing Typologies in India and Role of Artisans

NDMA

Unnati

PIC

19

Role of Artisans

To emphasize importance of the role of Masons as Guides to the society in constructing safer homes.

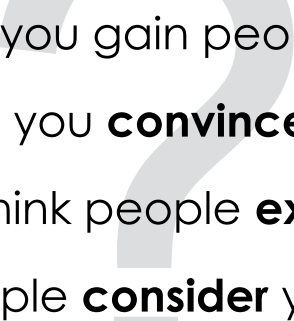

How will you gain people's **trust**?
How will you **convince** people?
What do you think people **expect** you to do?
What do people **consider** your role to be?

Let's make a list of what people think you can do and influence.

Discussion:

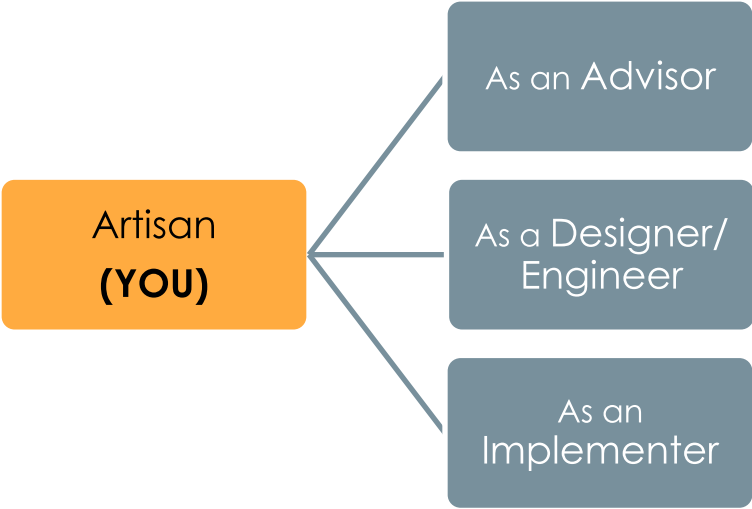

Discussion: Topics you should keep in mind while building with good quality construction for hazard resistance.

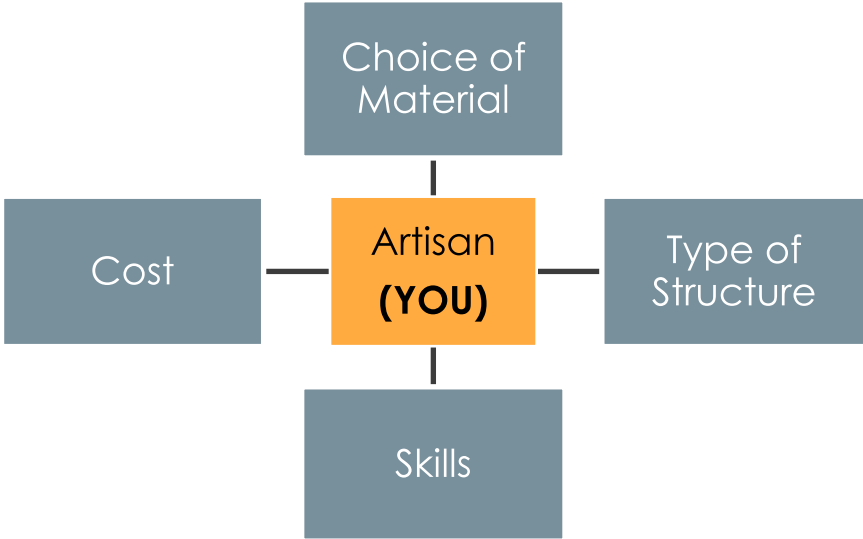

What is the risk of a Weak house on

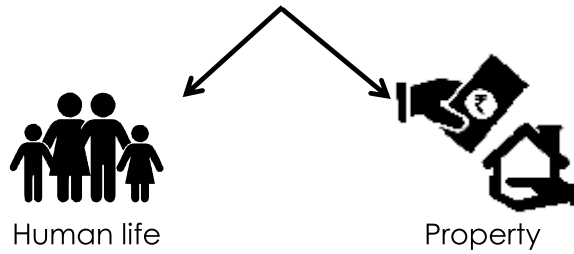

Hence, **strong** and **resilient** houses are needed.

What makes a house **strong**?

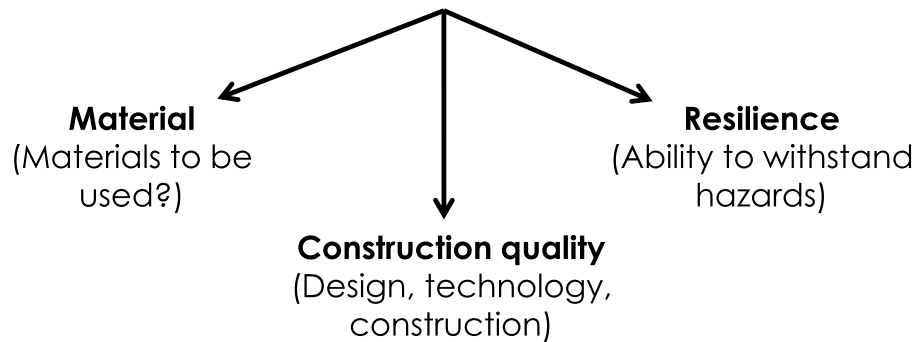

C3

Hazards: Their Severity, Zonation and Impact on Buildings

No. of Slides: 100
Time: 1 hour 30 min.



National Disaster Management Authority



Unnati
Organisation for Development Education



People in Centre

Expected Outcomes

1. Participants understand different hazards, their occurrences and frequency in the region.
2. Participants know about severity of disasters and methods of measuring their intensity.
3. Participants discuss different zones of hazards and locate their own region to relate with the intensity of possible hazards

Hazards



Earthquake



Flood



Cyclone



Tsunami



Landslide

EARTHQUAKES



Earthquake



Flood



Cyclone



Tsunami



Landslide

C3 Hazards: Their Severity, Zonation and Impact on buildings
NDMA Unnati PIC

3

Earthquake: Sudden Movement of the Earth's surface



C3 Hazards: Their Severity, Zonation and Impact on buildings
NDMA Unnati PIC

5



The Indian subcontinent has a history of earthquakes. The reason for the intensity and high frequency of earthquakes is the Indian plate driving into Asia at a rate of approximately, 49 mm/year.

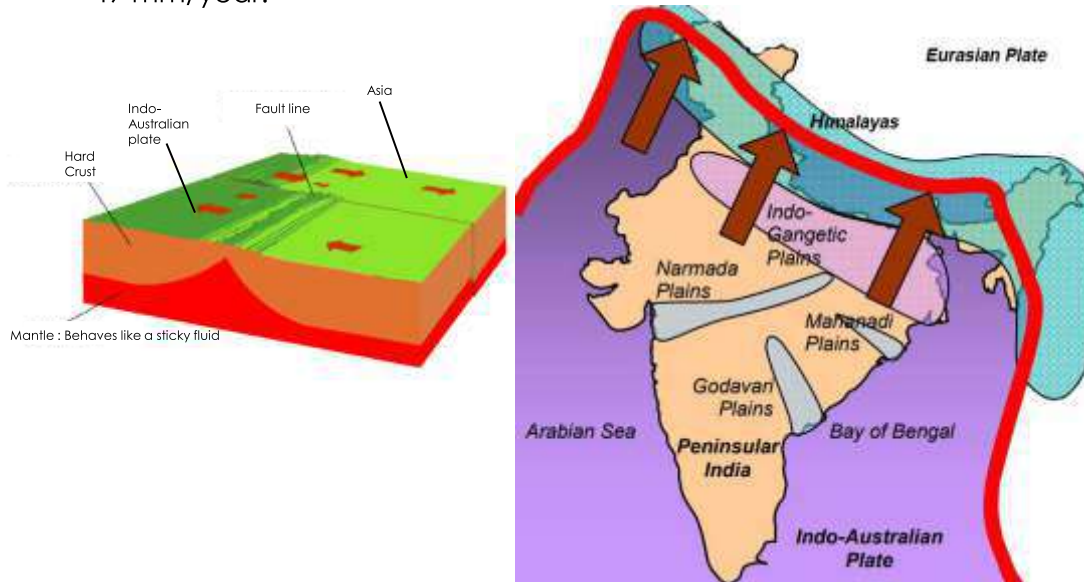

C3 Hazards: Their Severity, Zonation and Impact on buildings
NDMA Unnati PIC

6



Earthquake is a sudden shaking of the Earth, arising out of rupture at the tectonic plates.

Hypocentre is the first point on the fault when the rupture begins.

Epicentre is the point directly above the hypocentre on the surface of the earth.

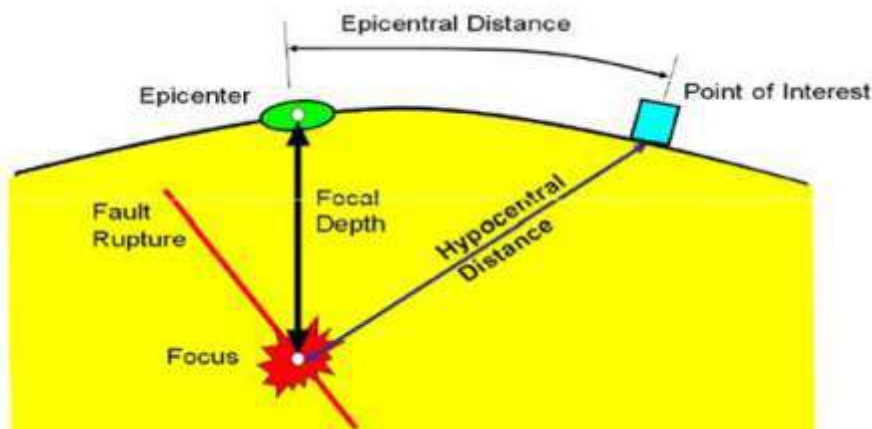

C3 Hazards: Their Severity, Zonation and Impact on buildings
NDMA Unnati PIC

7

Significant Earthquakes in India

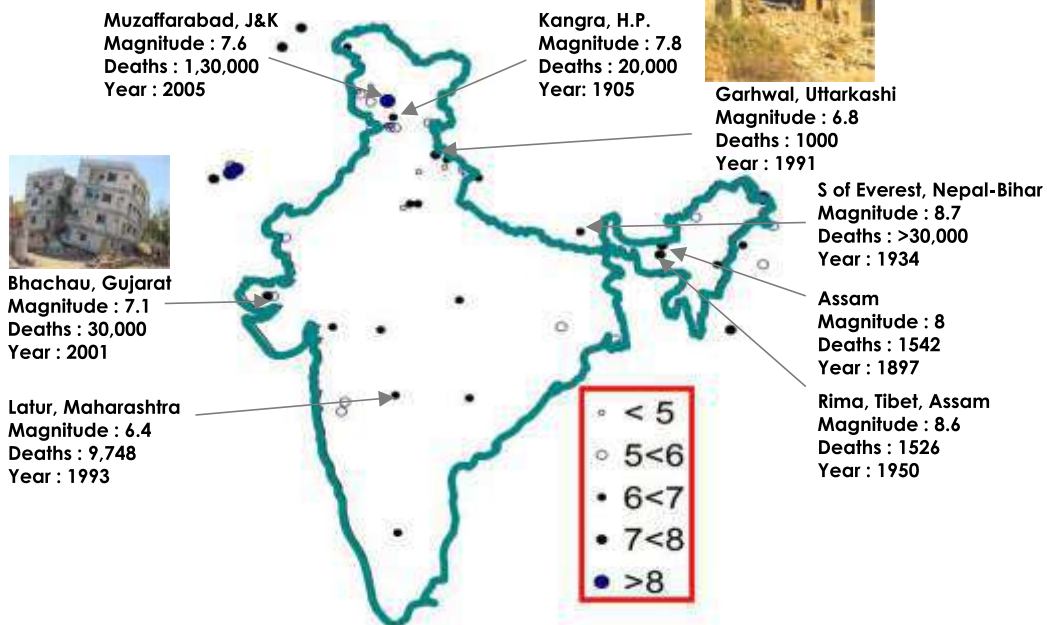

C3 Hazards: Their Severity, Zonation and Impact on buildings

NDMA

Unnati

PIC

8

The Damage at any given location is based on many other factors apart from the Magnitude, including:

1. Distance from the epicentre and hypocentre
2. Duration of the earthquake
3. The types of buildings at the specific location
4. The quality of the materials and construction techniques used in buildings in the area
5. Whether it triggers any other natural hazards

C3 Hazards: Their Severity, Zonation and Impact on buildings

NDMA

Unnati

PIC

9



Severity of an Earthquake

Bhuj Earthquake, 2001

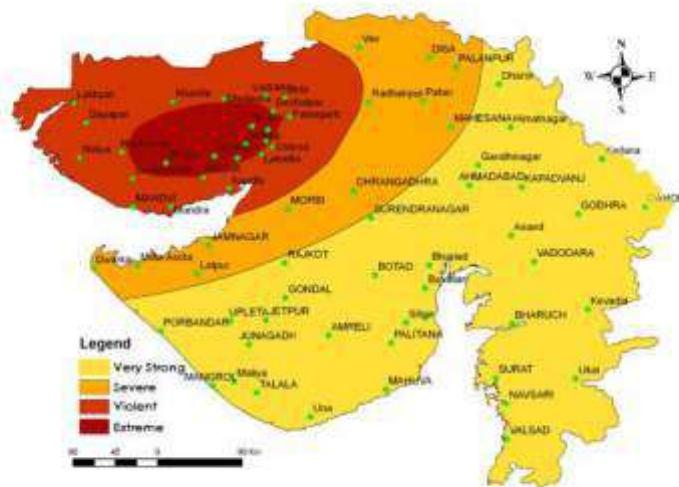

MMI Scale Map

C3 Hazards: Their Severity, Zonation and Impact on buildings
NDMA Unnati PIC

10



What is the difference between a 5.0, 6.0 and 7.0 magnitude Earthquake?

Energy released in a M7.0 earthquake is about 31 times that released in a M6.0 earthquake, and is about 1000 (*31x31) times that released in a M5.0 earthquake.

$$(M7.0): 31 \times (M6.0)$$

$$(M6.0): 1000 \times (M5.0)$$

The energy released by a M6.3 earthquake is equivalent to that released by the Atom Bomb dropped on Hiroshima (Japan) in the year 1945.

C3 Hazards: Their Severity, Zonation and Impact on buildings
NDMA Unnati PIC

11



EARTHQUAKE MAGNITUDE



shown in equivalence to the energy of the Hiroshima atomic bomb.

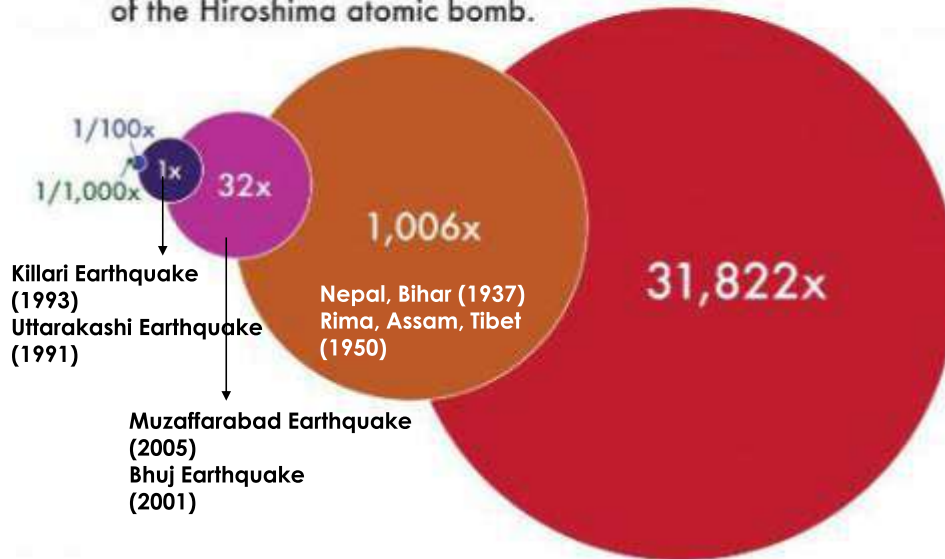

C3 Hazards: Their Severity, Zonation and Impact on buildings
NDMA Unnati PIC

Zonation

1. Which zone is your region in?
2. Is your region earthquake prone?
3. What may be the type of damage during an earthquake?

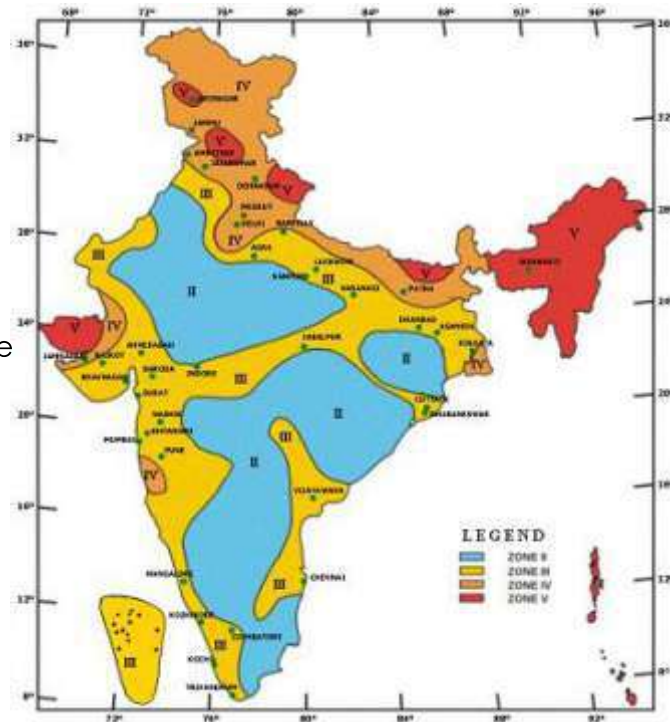

Source: Bureau of Indian Standards Seismic zone map of India.

C3 Hazards: Their Severity, Zonation and Impact on buildings
NDMA Unnati PIC



What are the forces acting on a house normally?

1. **Gravity Loads:** They act vertically downwards in a building. It comprises of Dead Loads (self weight of slab, columns, beams, walls, etc.) and Live Loads (additional weight imposed on the house by humans, furniture etc)
2. **Wind Loads:** These loads act horizontally on a building. Its intensity differs from place to place.



What are the forces acting on a house normally?

Load Path

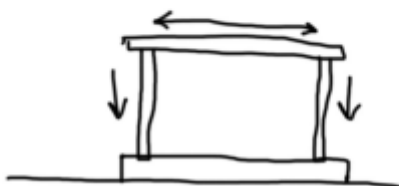
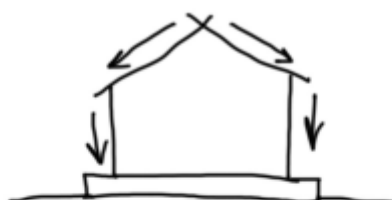



What happens during an earthquake?

Consider a person standing on a stationary bus, and then suddenly, the bus starts and lurches forward. What happens?

The person is thrown backwards, as if a force has been applied on his/her upper body.

Why does this happen?



C3 Hazards: Their Severity, Zonation and Impact on buildings
NDMA Unnati PIC

16



What happens during an earthquake?

The bus moves suddenly and so when the feet of the person move with the bus, the upper body is still in its initial position, owing to inertia.

During an earthquake, when the earth moves a similar situation occurs. This induces relative movement between the top and bottom of the house, resulting in stress in the walls. The earth and the plinth of the house move suddenly, while the walls or columns sustain stresses.

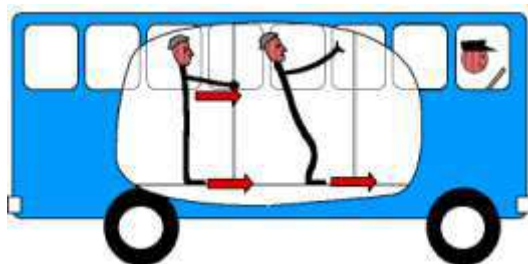

C3 Hazards: Their Severity, Zonation and Impact on buildings
NDMA Unnati PIC

17



Damage caused due to Shaking

As mentioned in the previous slide, the earth and the plinth of the house move suddenly, while the walls or columns sustain stresses due to inertia.

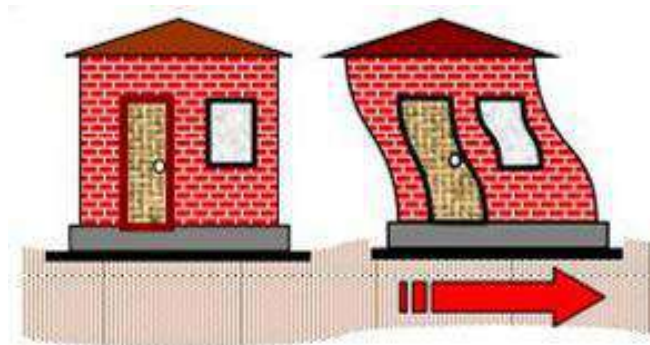

C3 Hazards: Their Severity, Zonation and Impact on buildings
NDMA Unnati PIC

18



Damage caused due to Shaking

All the loads must be transferred to the ground through the vertical members of the house (walls and/or columns). Here, heavier roof will have more inertia, and hence, more damage will be induced in walls and/or columns.

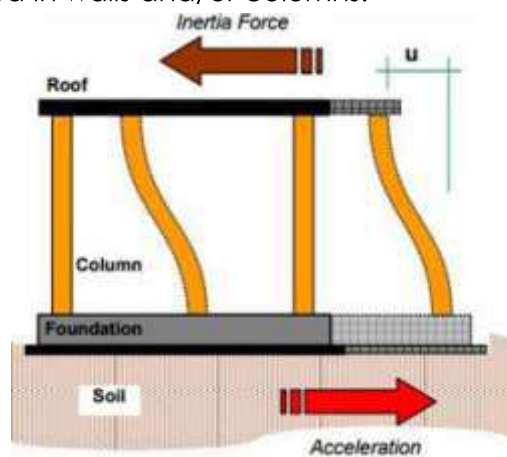

C3 Hazards: Their Severity, Zonation and Impact on buildings
NDMA Unnati PIC

19



Twisting movement of Houses

Imagine sitting on one side of a swing. As long as you are sitting in the middle, the swing moves equally. If you sit on one side, the swing starts to twist.



C3 Hazards: Their Severity, Zonation and Impact on buildings
NDMA Unnati PIC

20



Twisting movement of Houses

Similarly in a building, if one side is heavier than the other, during an earthquake, the building will twist and move more on the heavy side.

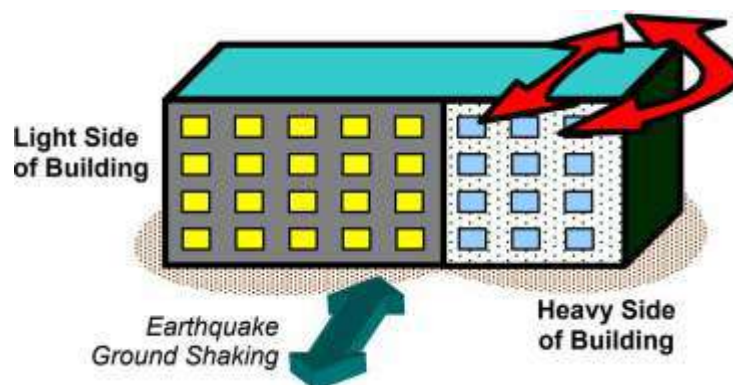

C3 Hazards: Their Severity, Zonation and Impact on buildings
NDMA Unnati PIC

21

Damage to Gable Wall



Cracks on the gable wall.

C3 Hazards: Their Severity, Zonation and Impact on buildings
NDMA Unnati PIC

22

Damage to Gable Wall



Collapse of the gable wall.

C3 Hazards: Their Severity, Zonation and Impact on buildings
NDMA Unnati PIC

23

Cracks around Openings



Diagonal cracks around openings

C3 Hazards: Their Severity, Zonation and Impact on buildings
NDMA Unnati PIC

24

Splitting of Thick Stone Wall



Delamination of stone wall

C3 Hazards: Their Severity, Zonation and Impact on buildings
NDMA Unnati PIC

25

Damage at Corners of Houses



Damage at the corners of the house.

C3 Hazards: Their Severity, Zonation and Impact on buildings
NDMA Unnati PIC

26

Damage at Corners of Houses



Separation of the wall from stone pier

C3 Hazards: Their Severity, Zonation and Impact on buildings
NDMA Unnati PIC

27

Damage to Wall



Out-of-plane damage to the exterior wall.

C3 Hazards: Their Severity, Zonation and Impact on buildings
NDMA Unnati PIC

28

Damage due to Soil Liquefaction



Damage due to foundation settlement

C3 Hazards: Their Severity, Zonation and Impact on buildings
NDMA Unnati PIC

29

Collapse of reinforced columns



Collapse of reinforced concrete columns (and building) during 2001 Bhuj (India) earthquake

C3 Hazards: Their Severity, Zonation and Impact on buildings
NDMA Unnati PIC

30

FLOODS



Earthquake



Flood



Cyclone



Tsunami



Landslide

C3 Hazards: Their Severity, Zonation and Impact on buildings
NDMA Unnati PIC

3



Introduction

A flood is rise of water in the land adjoining the house, which is usually dry.



C3 Hazards: Their Severity, Zonation and Impact on buildings
NDMA Unnati PIC

32



Regions in India prone to Floods

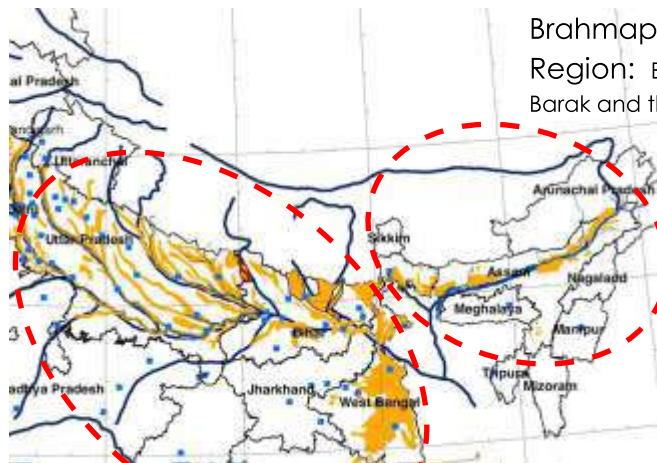

Brahmaputra River
Region: Brahmaputra and
Barak and their tributaries

Ganga River Region: consisting of
tributaries Yamuna, Sone, Ghaghra, Rapti,
Gandak, Burhi Gandak, Bagmati, Kamla
Balan, Adhwara group of rivers, Kosi and
the Mahanadi.

C3 Hazards: Their Severity, Zonation and Impact on buildings
NDMA Unnati PIC

33



Regions in India prone to Floods

North-west River Region:
The main rivers in this region are the Indus, Sutlej, Beas, Ravi, Chenab and Jhelum. These rivers are the tributaries of the Indus

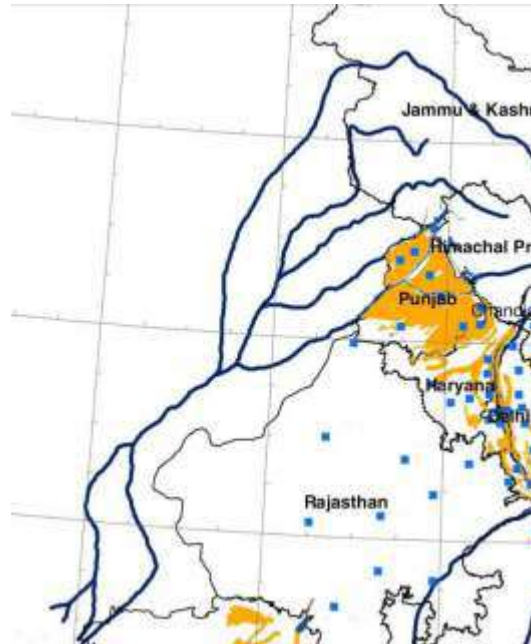

C3 Hazards: Their Severity, Zonation and Impact on buildings
NDMA Unnati PIC

34



Regions in India prone to Floods

The central India and Deccan Region:
Important rivers in this region are the Narmada, Tapi, Mahanadi, Godavari, Krishna and Cauvery

Coastline:
Storm Surge may cause flooding in settlements along the coast.

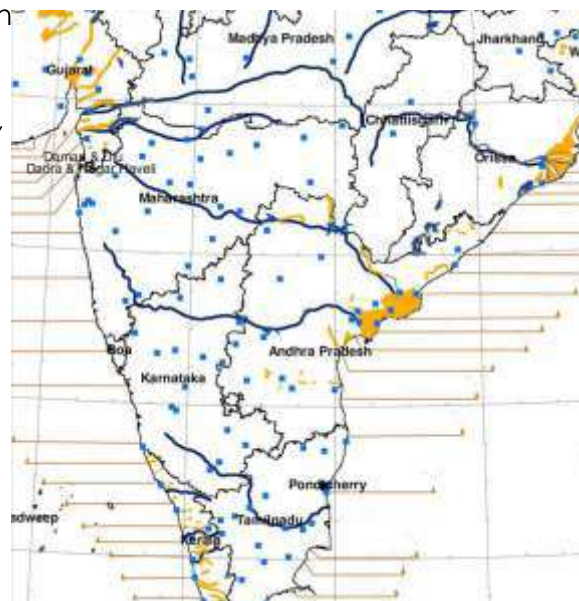

C3 Hazards: Their Severity, Zonation and Impact on buildings
NDMA Unnati PIC

35

Is your region flood prone?

What could be the primary cause of flooding in your region?

- due to rise in sea level
- due to heavy rainfall
- due to increased level of river water
- Due to poor choice of site for the houses in low-lying areas prone to flooding.

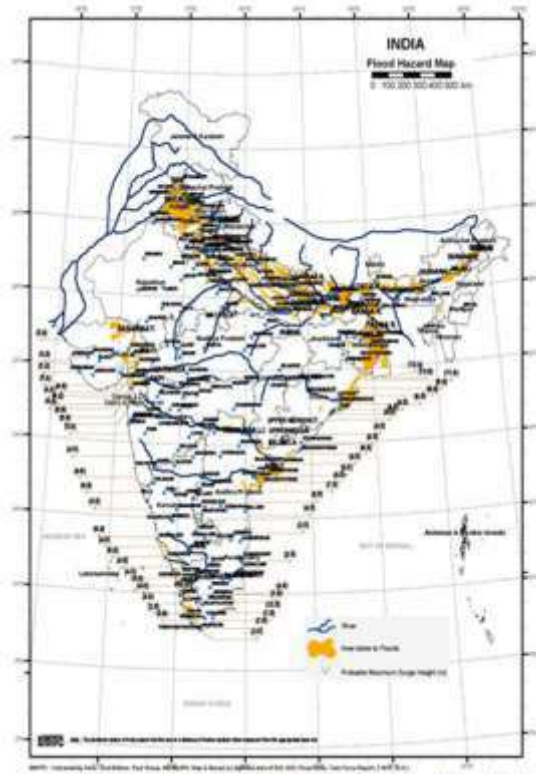

Source : <http://www.ndma.gov.in/en/vulnerability-profile.html>

C3 Hazards: Their Severity, Zonation and Impact on buildings

NDMA

Unnati

PIC

36



Severity of a Flood



C3 Hazards: Their Severity, Zonation and Impact on buildings

NDMA

Unnati

PIC

37



Measurement of Rainfall



RAIN GAUGE: An instrument that measures the amount of rain that falls in a given amount of time.

Information gathered from rain gauges report :

- How much rain a specific area has received, both for a single event and accumulation over time.
- Comparing current data to previous years helps gauge if an area is receiving too much or too little rainfall.

Significant Floods in India



Slow Fluvial Floods: Assam, Bihar (*Slowly rising floods of floodplains*)

The north-eastern states of India saw heavy rainfalls in July 2016 which resulted in flooding of various rivers.

Period of Time Flood water remained: July 1st to August 4th, 2016

Affected people: 34 dead and 7 Lakhs affected

Flash Floods: Bihar (*Floods due to dam breach*)

The Kosi Embankment near the Indo-Nepal border broke on 18 August 2008. The river changed course and flooded areas which had not been flooded in many decades.

The flood affected over 2.3 million people in the northern part of Bihar.

Period of Time Flood water remained: 3 July 2008 - September 2008

Affected people: 250 dead and nearly 30 Lakhs forced to evacuate



Significant Floods in India

Pluvial Floods: *Chennai (Floods due to extremely heavy rains and blocking the drainage systems)*

The 2015 South Indian floods resulted from heavy rainfall generated by the annual northeast monsoon in November–December 2015.

Period of Time Flood water remained: 8 November 2015 – 14 December 2015

Affected people: 500 dead

Various Causes of Floods

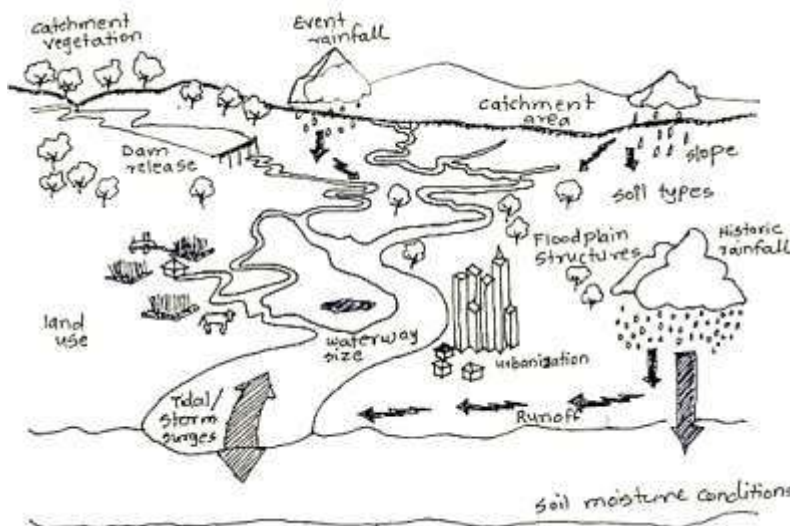

Catchment Area

1. The size, shape and land use of the catchment area.
2. Soil and Vegetation in and around the river.
3. The presence of structures in and adjacent to the waterway.

Event Rainfall

Specific rainfall depth, according to specific climate conditions recurring over a period of time.

Historic rainfall

Annual average rainfall

Urbanization:

1. Concrete buildings and road surfaces lead to Stormwater run-off
2. Buildings alter natural drainage paths, thereby leading to other low lying areas getting flooded.
3. Dam breaches due to mismanagement by authorities.



Impact on buildings

What happens when a large amount of water comes towards you with a force?



C3 Hazards: Their Severity, Zonation and Impact on buildings
NDMA Unnati PIC

42



Thrust Force

Flow of water: Flowing Water exerts a force on the walls of a house, and if the walls are weak, it carries with it everything that comes in it's way.



C3 Hazards: Their Severity, Zonation and Impact on buildings
NDMA Unnati PIC

43



What would happen, if a cardboard box is left submerged in water for a long period?



Cardboard loses its strength and becomes easy to tear.



The water would rise due to capillary action resulting in degradation of material, damaging the wall



Submergence

1. Prolonged period of exposure to water or moisture will cause loosely placed materials to become weak and vulnerable, because it leads to degradation of the strength of the materials.
2. When the water recedes, the submerged parts of the house may fail and cause damage to the house.
3. Some materials (thatch and earth) would degrade faster than others and would lose their capacity to carry the weight of the house





Excessive Moisture in the environment

Excessive rainfall and splashing of rainwater may cause the material (if it is earthen materials like adobe bricks) to lose their properties and to not be able to take the load of the roof anymore, resulting in collapse of the house.



C3 Hazards: Their Severity, Zonation and Impact on buildings
NDMA Unnati PIC

46



Erosion

Erosion of walls due to splashing: During heavy rainfall, the water splashes on the bottom part of the walls. If the house is made of a material which loses its strength when moist, then it may collapse.



C3 Hazards: Their Severity, Zonation and Impact on buildings
NDMA Unnati PIC

47

Erosion



Scouring of foundation: When water washes away loose material from the foundation, it may lead to severe damage or collapse of the house.



C3 Hazards: Their Severity, Zonation and Impact on buildings
NDMA Unnati PIC

48

Damage due to scouring of soil underneath the plinth



Damage to foundation is lessened due to plinth beam

C3 Hazards: Their Severity, Zonation and Impact on buildings
NDMA Unnati PIC

49

Damage to plinth due to thrust of water



Scouring of foundation

C3 Hazards: Their Severity, Zonation and Impact on buildings
NDMA Unnati PIC

50

Damage due to erosion of soil from under the house



Settlement of foundation.

C3 Hazards: Their Severity, Zonation and Impact on buildings
NDMA Unnati PIC

51

Damage to wall due to thrust of water



Damage to the substructure and superstructure

C3 Hazards: Their Severity, Zonation and Impact on buildings
NDMA Unnati PIC

52

CYCLONE



Earthquake



Flood



Cyclone



Tsunami



Landslide

C3 Hazards: Their Severity, Zonation and Impact on buildings
NDMA Unnati PIC

3



Introduction

An extremely large sized, powerful, and destructive air and water system from the sea swirling at very high speed, passes over land mass and causes destruction.



C3 Hazards: Their Severity, Zonation and Impact on buildings
NDMA Unnati PIC

54



Severity of a cyclone



Damage to the substructure and superstructure

C3 Hazards: Their Severity, Zonation and Impact on buildings
NDMA Unnati PIC

55



Causes of a cyclone

A cyclone is usually characterized by inward spiralling winds which occur due to pressure differences.

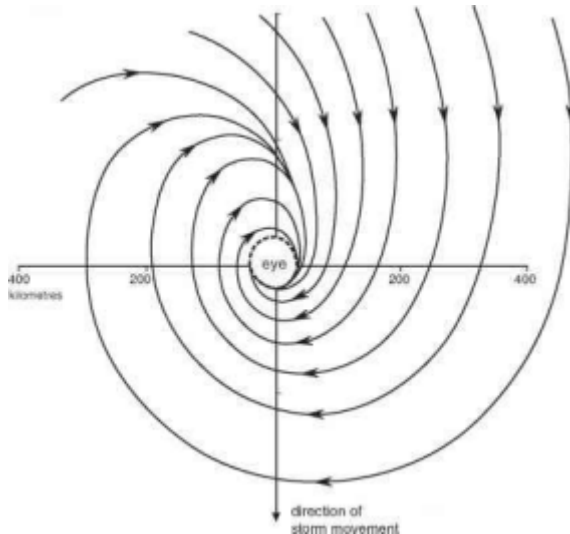

C3 Hazards: Their Severity, Zonation and Impact on buildings
NDMA Unnati PIC

56



Cyclones and Storm surges

A **storm surge**, **storm flood** or **storm tide** is a coastal flood or tsunami-like phenomenon of rising water commonly associated with low pressure weather systems (such as tropical cyclones and strong extratropical cyclones), the severity of which is affected by the shallowness and orientation of the water body relative to storm path, as well as the timing of tides.

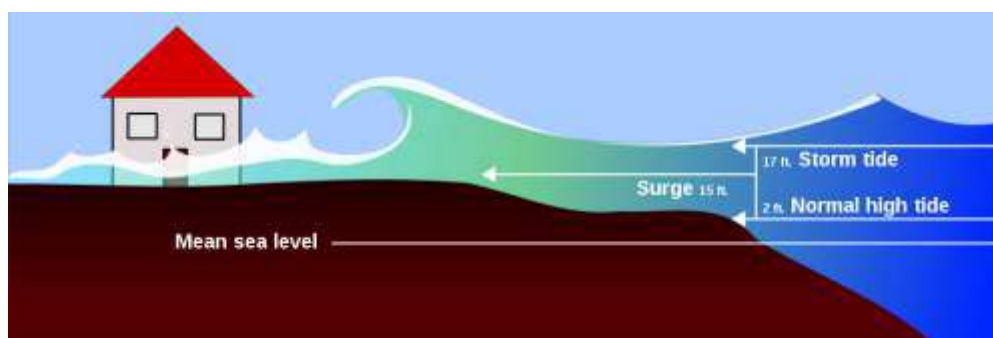

C3 Hazards: Their Severity, Zonation and Impact on buildings
NDMA Unnati PIC

57



Type of Disturbance	Associated Wind Speed in the Circulation
Low pressure area	< 31 kmph
Depression	31 – 49 kmph
Deep Depression	50 – 61 kmph
Cyclonic Storm	62 – 88 kmph
Severe Cyclonic Storm	89 – 118 kmph
Very Severe Cyclonic Storm	119 – 221 kmph
Super Cyclonic Storm	221 kmph and above

Significant Cyclones in India



Odisha cyclone 1999 (Super Cyclonic Storm)

The 5-6 m (16-20 ft) surge brought water up to 35 km (20 mi) inland. The surge combined with heavy rains to produce widespread flooding, damaging around 1.6 million homes. Almost all the trees were flattened out.

Peak Wind Speed: 260 km/h

Intensity: 912 mbar

Deaths: 9,887 fatalities (2000 because of flood)

Cyclone Vardah, Tamil Nadu 2016 (Very Severe Cyclonic storm)

The cyclone prompted India's largest evacuation of 16,000 people. Vast devastation was caused to trees and property.

Duration: 6th December- 13th December

Peak Wind Speed: 130 km/h (3 min)

Intensity: 982 mbar

Deaths: 24 fatalities



Gujarat Cyclone 1998 (Very Severe Cyclonic storm)

Brought a large storm surge of 4.9 m (16 ft) which devastated coastal communities and salt mine workers who didn't receive warning of the cyclone.

Peak Wind Speed: 165 km/h (3 min)

Intensity: 958 mbar

Deaths: Atleast 10,000

Measuring Wind Speed

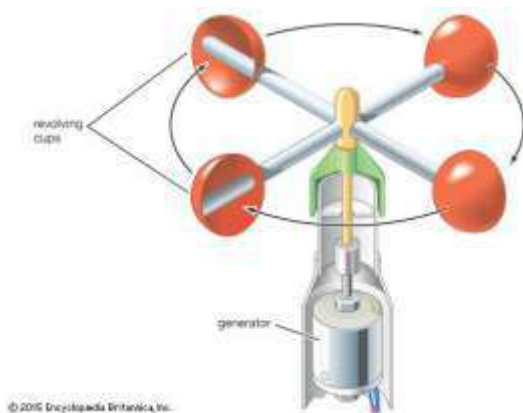

An **Anemometer** is a device used for measuring the speed of wind, and is also a common weather station instrument, which is placed at a height of 10m from the ground level.

Is your region cyclone/windstorm prone?

Which of the following risk zones does your region fall in ?

-  Very high damage risk Zone – A
-  Very high damage risk Zone – B
-  High damage risk zone
-  Moderate damage risk zone – A
-  Moderate damage risk zone - B
-  Low damage risk zone



Source : <http://www.ndma.gov.in/en/vulnerability-profile.ht>



Impact on Houses

Uplifting or Uprooting of roof or house

When you are walking in a place where fast winds are blowing, your umbrella is overturned or blown off.



C3 Hazards: Their Severity, Zonation and Impact on buildings

NDMA

Unnati

PIC

63



Uplifting of Roof or House

Roofs that aren't anchored properly can get uplifted during a cyclone/windstorm.

Light weight temporary shelters, which are not held properly, may blow away.

CGI sheets/tiles could blow away if not anchored well.

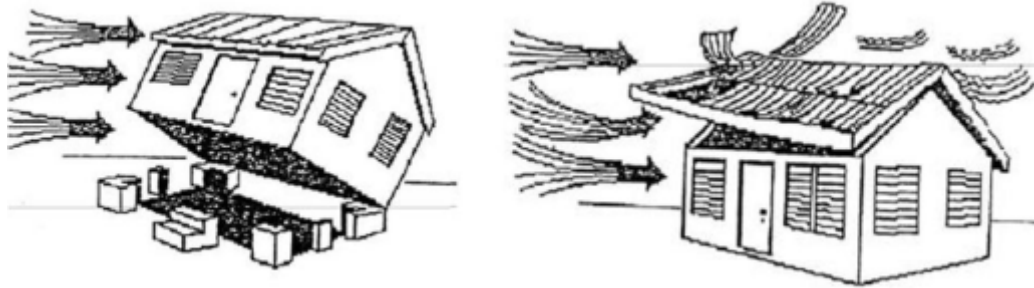

C3 Hazards: Their Severity, Zonation and Impact on buildings
NDMA Unnati PIC

64



The pressure of the wind builds up on the ceiling inside the house to such an extent that the clay tiles are blown away.



C3 Hazards: Their Severity, Zonation and Impact on buildings
NDMA Unnati PIC

65



All the roofing material has been blown away due to the outward/upward pressure of the wind.



C3 Hazards: Their Severity, Zonation and Impact on buildings
NDMA Unnati PIC

66



Erosion due to accompanying excessive rainfall

Cyclones are accompanied by periods of excessive rainfall that lead to flooding and/or splashing. Therefore, damage occurs to the house due to erosion and presence of excessive moisture in the air, leading to the reduced strength of the materials.

C3 Hazards: Their Severity, Zonation and Impact on buildings
NDMA Unnati PIC

67



Earthquake versus Cyclone

During an earthquake, lighter the building and the roof, the better is the performance of the house. Lighter roof would not induce as much load on the walls, and the walls would be able to transfer the loads easily during an earthquake.

On the other hand, **during a cyclone, heavier the roof, the better is the performance of the house.** It would resist strong loads due to the wind pressure, hold itself and the house in place.



Damage due to High Pressure of Wind



Severe damage to load bearing structures



Damage to Rear Wall due to Outward Wind Pressure



Severe damage to load bearing structures

C3 Hazards: Their Severity, Zonation and Impact on buildings
NDMA Unnati PIC

70



Damage due to High Pressure of Wind



Damage to roof structure

C3 Hazards: Their Severity, Zonation and Impact on buildings
NDMA Unnati PIC

71



Collapse due to High Pressure of Wind



Damage to roof structure

C3 Hazards: Their Severity, Zonation and Impact on buildings
NDMA Unnati PIC

72

TSUNAMI



Earthquake



Flood



Cyclone



Tsunami



Landslide

C3 Hazards: Their Severity, Zonation and Impact on buildings
NDMA Unnati PIC

3

Introduction



A large oceanic wave, usually caused by earthquakes



C3 Hazards: Their Severity, Zonation and Impact on buildings
NDMA Unnati PIC

74

Severity of a Tsunami



C3 Hazards: Their Severity, Zonation and Impact on buildings
NDMA Unnati PIC

75

Measuring a Tsunami



A tsunami is a series of large waves caused by the displacement of a large volume of water, as a result of an earthquake, an underwater landslide, or a volcanic eruption.

Usually, it takes an earthquake with a Richter magnitude exceeding 7.5 to produce a destructive tsunami.

A tsunami forecast can be made, by laying out a DART system on the ocean bed, which transmits data in real time.

Significant Tsunamis in India



Indian Ocean Tsunami of 2004



Source:
http://www.sangam.org/2007/12/Tsunami_Rehab.php?uid=2692&print=true

The Tsunami was caused by an earthquake, its epicentre close to the island of Sumatra in Indonesia. Severe damage occurred at the coastlines of India, Sri Lanka, Indonesia and Malaysia.

Water level rose to 20 m high and come up to 2km inland along the Indian coast.

Affected people: 230,000–280,000 dead and more missing
Magnitude of Earthquake: 9.1-9.3

Is your region tsunami prone?

When was the last warning issued or a tsunami struck?



Source: Survey of India Tide Gauge Network

Impact on Houses



What happens when an extremely large force of water completely engulfs a house?

1. Due to its force and quantity, it may cause the entire house to be razed to the ground or be carried away with the water during inflow and outflow of the waves.
2. Tsunami is followed by a flood and so the presence of water for a prolonged period causes further damage to houses.

Impact of a Tsunami



A large thrust force either razes the house or gets it uninged from the ground and carries it away along with the water.



C3 Hazards: Their Severity, Zonation and Impact on buildings
NDMA Unnati PIC

80

Seawater creates havoc



C3 Hazards: Their Severity, Zonation and Impact on buildings
NDMA Unnati PIC

81

Seawater Floods Low Lying Areas



C3 Hazards: Their Severity, Zonation and Impact on buildings
NDMA Unnati PIC

82

LANDSLIDE



Earthquake



Flood



Cyclone



Tsunami



Landslide

C3 Hazards: Their Severity, Zonation and Impact on buildings
NDMA Unnati PIC

3

Introduction



Rapid downward movement of a mass of rock, earth, or artificial fill on a slope



C3 Hazards: Their Severity, Zonation and Impact on buildings
NDMA Unnati PIC

84

Severity of a Landslide



C3 Hazards: Their Severity, Zonation and Impact on buildings
NDMA Unnati PIC

85

Is your region landslide prone?
 Was your region highly, moderately or marginally affected?



NATURAL CAUSES

1. Erosion due to water and wind
2. Weakening of a slope
3. Earthquakes

MAN-MADE CAUSES

1. Deforestation, cultivation and construction
2. Vibrations from machinery or traffic.
3. Blasting and mining



Significant Landslide in India

1. *Malin Landslide, Maharashtra (2014)*, due to heavy rainfall
Fatalities: 151 deaths, 40 houses damaged
2. *Kedarnath Landslide, Uttarakhand (2013)*, due to uttarakhand floods. Fatalities: 5748 deaths, 4200 villages affected
3. *Amboori Landslide, Kerala (2001)*, due to heavy rainfall
Fatalities: 38 deaths



Impact on buildings: High Impact force

The mass of earth coming down from the mountain is like a large hammer laying on the side of the house.





High Impact Force

The boulders or mass coming down with a landslide exerts a thrust force on the side of a house. This may cause the entire house to be damaged or a part of it to just be taken away along with the mass.



C3 Hazards: Their Severity, Zonation and Impact on buildings
NDMA Unnati PIC

90



Sliding Force

When the land on which a house rests undergoes movement, the house may slide down along with the ground underneath, thereby damaging itself as well as other buildings downslope.



C3 Hazards: Their Severity, Zonation and Impact on buildings
NDMA Unnati PIC

91

Landsliding from underneath the House



Damage to sub-structure

C3 Hazards: Their Severity, Zonation and Impact on buildings
NDMA Unnati PIC

92

Which Hazard can lead to which other Hazards?



Earthquake



Flood



Cyclone



Tsunami



Landslide



Earthquake



Flood



Cyclone



Tsunami



Landslide

Often, one hazard results in another one. In case of such cascading hazards, the possibility of damage and loss of life is increased.

C3 Hazards: Their Severity, Zonation and Impact on buildings
NDMA Unnati PIC

93

An Earthquake may lead to ...

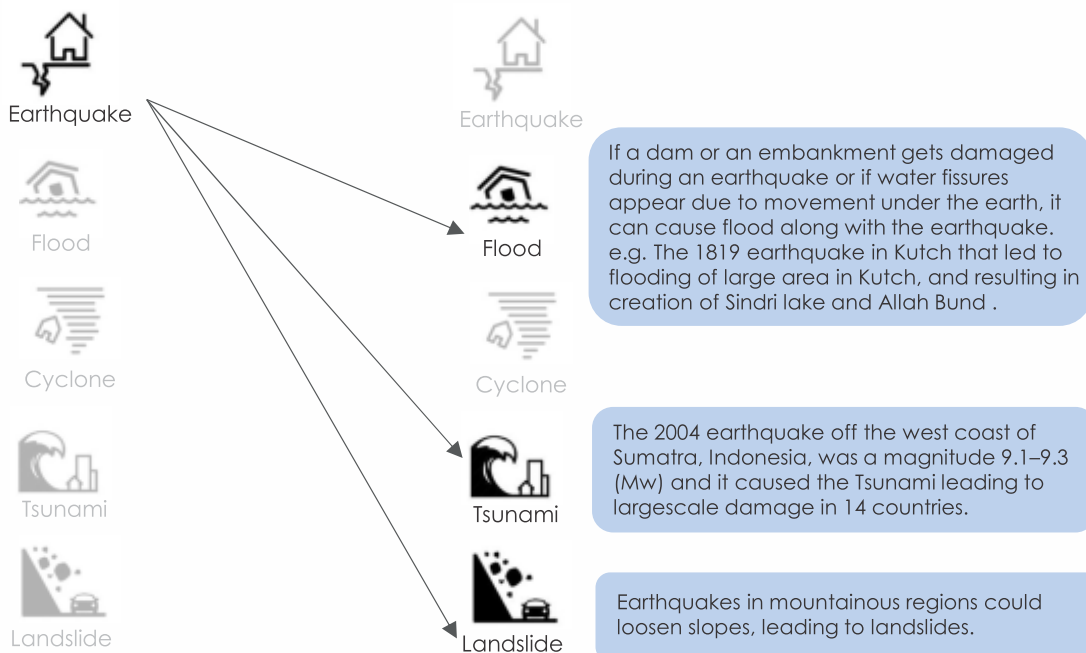

A Flood may lead to ...



A Cyclone may lead to ...



Since cyclones usually occur near the coastal areas, they bring along huge waves and often are accompanied by rains, resulting in flooding of the area. Kutch, Orissa, Andhra Pradesh has experienced several such cyclones and floods.

A Tsunami may lead to ...



Water that comes in due to a tsunami leads to severe flooding and prolonged submergence, resulting in damage to homes. 2004 Indian Ocean Tsunami caused flooding at several places along east coast of India as well as other places

The large volume of water may cause loose slopes to come down or be tipped off. Local landslides were observed post 2005 Tsunami at places

A Landslide may lead to ...

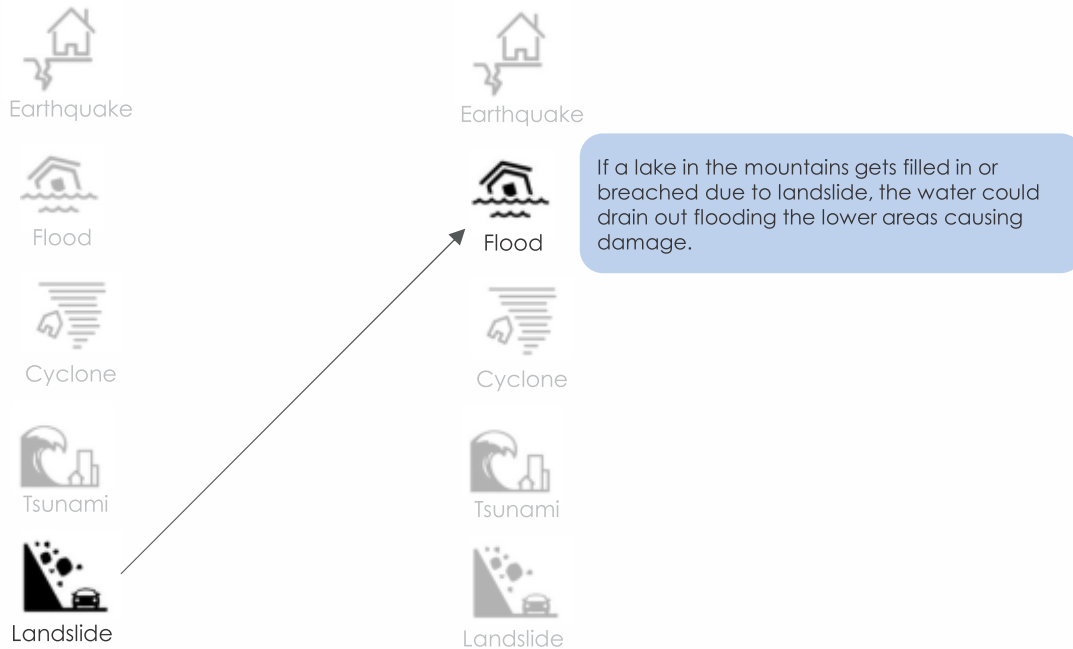

Summary

1. We looked at the different disasters (Earthquakes, Cyclones, Floods, Tsunamis and Landslides), and where and with what intensity they occur in India.
2. Earthquakes occur due to shift in plates of the earth's surface. India has a high frequency of earthquakes. The magnitude (measured from the energy released) rises logarithmically with increase in the numerical digit. Earthquakes can cause flood, tsunami and landslide. We discussed the damage due to shaking and how loads in the horizontal direction need to be transferred to the ground. Also, we discussed twisting of houses that are asymmetric.
3. Floods can be caused when a house is built in a low-lying area, where water level rises because of the river changing its course, heavy rainfall or gradual rising of water. We discussed damage due to submergence, flow of water, splashing of rainwater and presence of moisture in the air.

Summary

4. Cyclones are common along the coast of India. The intensity of the cyclone is measured by measuring the speed of the wind. A cyclone may be accompanied by heavy rainfall and floods. We discussed the pressure of the wind, suction and erosion due to accompanying excessive rainfall.
5. Tsunami is typically caused by an Earthquake. It's severity depends on how high the wave is and how far inland does it come in. We discussed shear force and accompanying floods
6. Significant Landslides in India are caused by natural and man-made effects. The thrust force of a land mass coming down or the sliding action, if the house is on the land mass, is what causes severe damage.
7. Multiple disaster events may occur when one disaster triggers another in quick succession, and causes severe effects and losses.

P4

Quality of Materials and Importance of Tools

No. of Slides: 29
Time: 1 hour 30 min.



National Disaster Management Authority



Unnati
Organisation for Development Education



People in Centre

Expected Outcomes

1. Participants understand the importance of good quality materials
2. Participants develop knowledge about construction tools and appropriate ways of handling them.
3. Trainers evaluate the existing knowledge of the participants in using different tools.

Know your Construction Materials

The participants should be divided into groups of two, and then, each of these groups should be given three samples of the materials to be tested.

Tests for Brick

TEST	EXPERIMENT	OBSERVATIONS	RESULTS
Drop Test: A brick should not break when dropped flat on hard ground from a height of about 1m.			
Sound Test: When two bricks are struck against each other by the two hands of the same person, there should be clear ringing sound indicating well fired brick.			
Scratch Test: A good burnt brick has its surface so hard that the fingernail cannot scratch it.			
Appearance: Shape Checking overall shape, edges and frog, and see if it is a perfect cuboid			
Comparison: Are they all more or less of the same size or they have high variations in their size?			

P4 Quality of Materials and Importance of Tools

NDMA

Unnati

PIC

4

Brick Quality



Edges and shape of a good quality brick

Uneven edges and poor quality brick

P4 Quality of Materials and Importance of Tools

NDMA

Unnati

PIC

5

Tests for Stone

TEST	EXPERIMENT	OBSERVATIONS	RESULTS
Drop Test: When dropped from a height of about 1m, it must retain its integrity and not break			
Shape: Should not be flaky, rounded or smooth			
Consistency: Should have varying sizes to be able to do proper bonding			

Stone Quality



Texture of good quality stones



Texture of poor quality, flaky stones



Properly shaped stones with straight edges



Poorly shaped stones, rounded edges

Don't use Rounded Stones

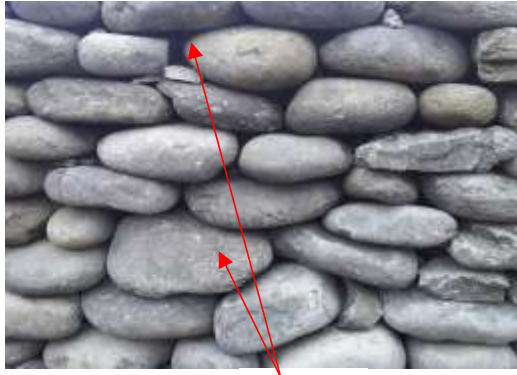

Rounded stones



Angular stones

Never use round stones for making a house. Round stones are slippery. So, a wall made with them is unstable.

Stone should be broken to make it angular (so that it has no rounded faces), and to enable better bonding.

Tests for Sand

TEST	EXPERIMENT	OBSERVATIONS	RESULTS
<p>Well graded sand: The sand should have a select range of grain sizes and their suitable composition. Check by observing the Grains carefully.</p>			
<p>Salt content/ Salinity: The sand should not have any salt content. Check by tasting the sand.</p>			
<p>Purity: The sand should be free from all organic matter. Check for organic and degradable materials or any other materials mixed with the sand</p>			

Tests for Sand

The following need to be checked in Sand before using it in the construction of house:

1. Sand must be angular for more stability.
2. Only fine sand must be used for plastering.
3. Sieve sand to remove small pebbles.
4. Silt content in sand should not be more than 10%.
5. Remove silt by pouring sand against the wind or by washing.



To check silt content in sand, put some sand in a transparent jar, add water, shake it well and put it down so that all of it settles down and water becomes clear. The thickness of very fine powder at the top divided by the total thickness of soil in the jar gives the % of silt in the soil.



Tests for Concrete Blocks

TEST	EXPERIMENT	OBSERVATIONS	RESULTS
Drop test: The concrete block should not break when dropped flat on hard ground from a height of about one meter.			
Shape: Overall shape, edges and size should be constant.			
Surface Test: The side to be bonded must be rough.			

Concrete Blocks



Good Quality Concrete blocks with straight Edges

Poor Quality Concrete blocks with broken edges and not cured properly

P4 Quality of Materials and Importance of Tools
NDMA Unnati PIC

12

Tests for Wood

TEST	EXPERIMENT	OBSERVATIONS	RESULTS
Type: Quality Identifying species, colour, texture, grains and smell.			
Size and Shape: Check the Section size, straightness, knots, soft and hard.			
Infection: Check for presence of borers.			
Seasoned Wood: Wood used for construction should be well seasoned and dry.			

P4 Quality of Materials and Importance of Tools
NDMA Unnati PIC

13

Tests for Bamboo

TEST	EXPERIMENT	OBSERVATIONS	RESULTS
<p>Type: Species of bamboo, and distance between knots, columns and roof members should be a min. of 70-100mm at the thin end. Wall thickness of bamboo should not be less than 10 mm. The distance between nodes shouldn't exceed 600 mm. Lesser the distance between nodes, stronger it is.</p>			
<p>Physical Quality: Maturity (not less than 3 years), thickness, taper, straightness and diameter</p>			
<p>Infection: Check for presence of borers.</p>			

P4 Quality of Materials and Importance of Tools
 NDMA Unnati PIC

14

Bamboo Quality



1 year old bamboo



Thick bamboo



3 year old bamboo



Thin bamboo

P4 Quality of Materials and Importance of Tools
 NDMA Unnati PIC

15

Tests for Steel

TEST	EXPERIMENT	OBSERVATIONS	RESULTS
Physical attributes: Check ISI mark, TOR/TMT Steel and specified diameter. Re-rolled steel to be avoided. Check for Manufacturer's Certificate of Compliance with the Standards.			
Corrosion: Check for Corrosion			

Tests for Cement

TEST	EXPERIMENT	OBSERVATIONS	RESULTS
Physical attributes: ISI mark, Grade of cement, Uniformity of colour, Moisture content (no lumps)			

Know your Construction Tools

Common construction tools (like spade, bucket, plumb bob, thread, measuring box and levelling tube) are introduced during this session, and it is tested whether the participant knows how to use them.

Each group builds 4-5 layers of masonry wall of about 1m length in brick, stones or blocks.

Trainer makes observations on whether they use common construction tools properly (like measuring tape, spirit level, L-angle, plumb bob, thread, measuring box, levelling tube and trowel).

P4 Quality of Materials and Importance of Tools
NDMA Unnati PIC

18



Plumb Bob and Thread



Spirit Level



L angle



Trowel



Measuring Box

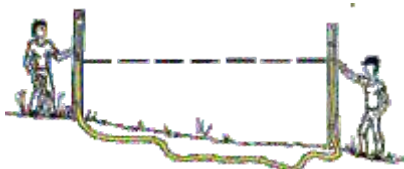

Levelling Tube



Measuring Tape

P4 Quality of Materials and Importance of Tools
NDMA Unnati PIC

19

Line Out

Line out of Simple House using 3-4-5 Right-Angle Rule and other shapes, if required.

Each group can draw a shape (rectangle, arched, etc.) and other groups can check, comment and point out mistakes, if any. There can then be discussion on what are alternative ways of laying it out.

Cleaning Up and Levelling the Site

The site must be cleared up and organised for source of water, place for mixing mortar, etc.

Laying of Bricks

Bricks should be soaked and used wet when cement mortar is being used.

Wetting Concrete Blocks, Soft Stone and Bricks



Thoroughly soak the Brick, Concrete Block or soft stone in water before using them in masonry with mortar to ensure strong masonry walls.

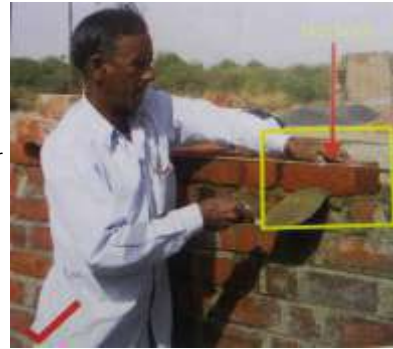

Laying of Bricks

The frog of the brick must face upwards

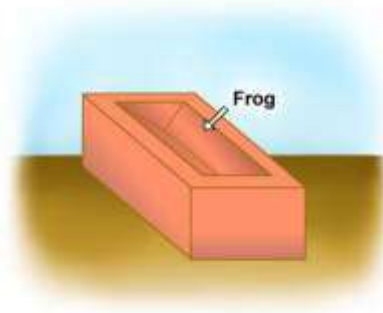

Always place bricks with its frog (groove mark) facing up to ensure placement of mortar in it for better bond between courses.

Laying of Bricks

The Plumb Line only needs to be used at the ends of walls. Use a string to get a straight wall in between.

The Plumb Line should always fall to the bottom course, not to the brick immediately below.

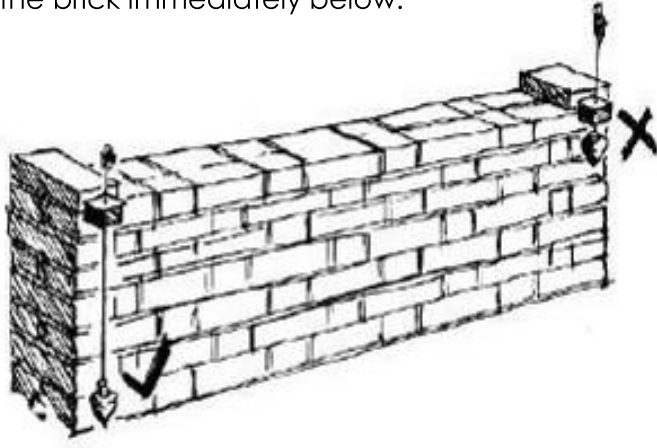

1. Cement Selection

43 Grade cement is preferred over 53 Grade cement for the construction of houses and small infrastructure buildings.

2. Curing of Cement Mortar/Concrete

Cement mortar becomes stronger by keeping it wet continuously without letting it dry. Keep it wet for a minimum 10 days and to get maximum strength keep it wet for 28 days.

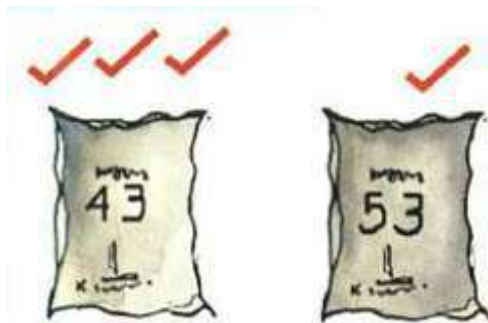

Rules for Aggregates

Do not use aggregates larger than 30mm size.



Do not use round aggregates from river. They have a poor bond with cement and so produce weaker concrete.



Rules for Steel Reinforcement Bars



Never connect two rods through hooks at their ends.



Connect one steel bar to another through an overlapping joint. Overlap length should be 50 times Bar Diameter long, and tied at four to five places with binding wire.

Rules for Cover in Reinforced Concrete



Steel bars used in RC slab must have a minimum clear concrete cover of 15mm.



Steel bars must be fully encased in concrete to utilize full strength of steel bar.

Points for Discussion

We now know how to check the quality of various materials, and how to prepare them for use in the construction of houses.

Lets summarise the following with regards to the materials for construction.

1. Points to consider for selecting the materials as given: Bricks, stone, sand, steel, bamboo, timber
2. While working with these materials, what are the appropriate methods and check-points:
 - Masonry with bricks,
 - Masonry with stone, and
 - Concreting for beams, bands, columns and slabs.
3. Before beginning the construction, what are the steps to be followed and why?

C5

Principles of Hazard Resistant Construction

No. of Slides: 46

Time: 1 hour



National Disaster Management Authority



Unnati

Organisation for Development Education



People in Centre

Recollection

Various housing typologies exist in a region.

It is possible to make all of these typologies safe?
Why is it important for different typologies to exist?

We must ensure different typologies continue so that the cultural identity of different communities continue to flourish and skills and knowledge of using different materials evolves in a manner such that it is appropriate to that region and context. These building typologies have evolved over generations, each responding suitably to the local climate. However, they need to be analyzed for their hazard resistance capabilities in the present times.

Response to prevalent hazards is necessary.

How do we decide which hazard to build resistance against?

We must check the local history and the zone in which our region falls to know which hazards we need to increase the resistance of our homes against.

Recollection

Different hazards are prevalent in varying degrees across India.

What are the various **forces that impact houses** during different hazards?

How do we check **quality of materials** during construction?

Why is the quality of materials important for hazard resistance?

Quality of construction and the quality of materials used is critical because the inconsistencies in sizes and techniques, use of weak materials, or badly-made details will prove to be the first to fail during a hazard.

Expected Outcomes

1. To develop understanding on Hazard Resistant Construction technologies and materials to reduce risk and minimise loss of life
2. Contextualising the vulnerability in local construction

Effects that impact the performance of Houses against different hazards



Earthquake: Inertia, shaking, twisting



Flood: Thrust force, erosion, submergence, splashing



Cyclone: Uplifting, suction, pressure, rainfall



Tsunami: Impact of tidal wave



Landslide: Impact of mass of earth, sliding

Principles of Hazard Resistant Construction

If any of the above effects impacts our houses during a hazard:

1. **A house must be able to retain it's original shape or come back to its original shape.**



Principles of Hazard Resistant Construction

If any of the above effects impacts our houses during a hazard:

2. **All the main elements of a house must be able to sway back and forth during an earthquake, or any other hazard, withstand the stresses and other effects with some damage, but without collapse.**



Principles of Hazard Resistant Construction

If any of the above effects impacts our houses during a hazard:

- 3. Every junction and connection must be so constructed to be capable of transferring the inertia forces through them to the ground.**

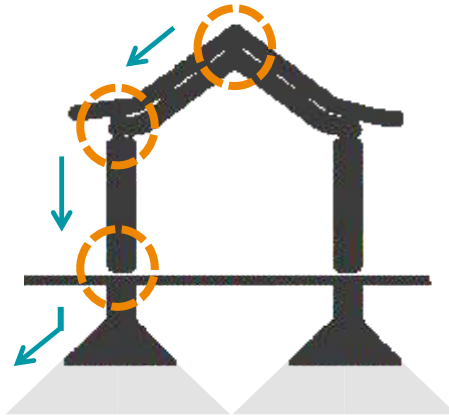

Principles of Hazard Resistant Construction:

If any of the above effects impacts our houses during a hazard:

- 4. Alternate load path design:**

If one element weakens along the load path, the house must be capable of transferring the load through an alternate path to avoid collapse.

Alternate load path design

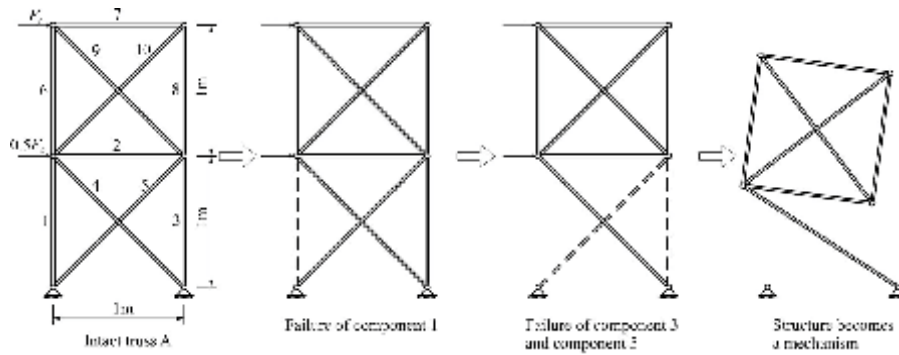

In usual condition, part of the load travels from 7 to 6 to 1 to ground. In case of failure of element 1, the load is then transferred to elements 2 and 4, hence choosing alternate paths 7 to 6 to 4, 7 to 6 to 2 to 3 and 7 to 6 to 2 to 5, thus preventing a collapse of the house.

Design Principles

The principles that help a house resist the effects imposed on it are:

1. Structural Robustness,
2. Structural Integrity,
3. Elasticity,
4. Ductility,
5. Bracing, and
6. Design of elements of the house to protect from wind and water.

1. Structural Robustness

Robustness is the ability of a **house** to withstand events (like fire, explosions, impact or the consequences of human error), without being damaged to an extent disproportionate to the original cause.

Example of robustness,

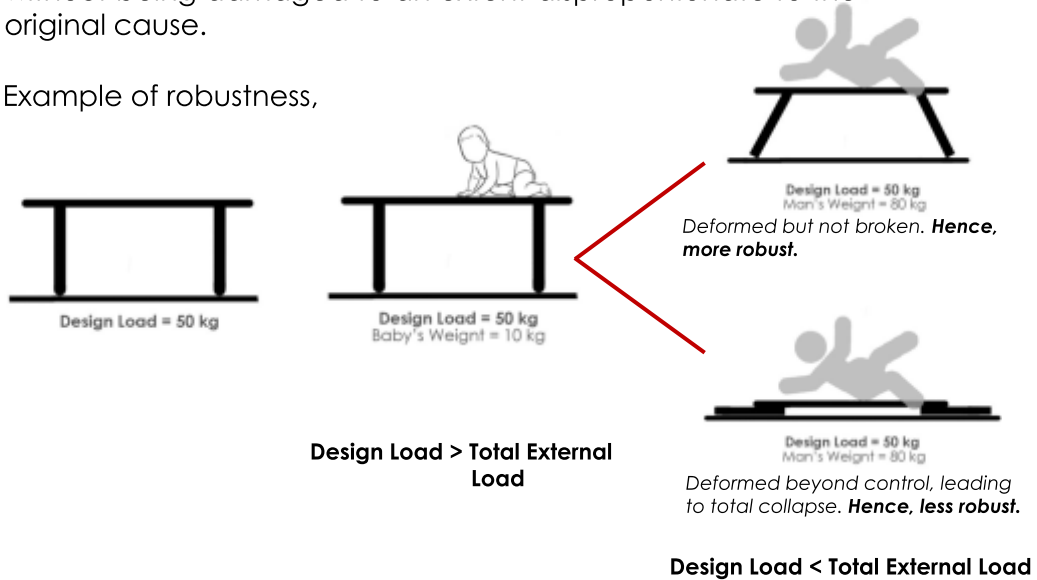

How to achieve Structural Robustness?

Design Loads need to be considered with respect to the location and the severity of hazards in that region.

1. Good quality of materials
2. Good workmanship and construction techniques
3. Hazard Resistant design (Architectural and Structural)

2. Integrity

All elements of the house must be tied well to each other.

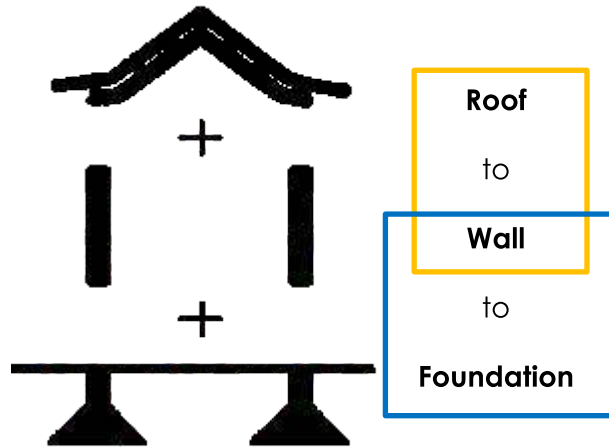

Box Action (Load Bearing Construction)

Imagine a cardboard box. When we apply a horizontal force on it, the entire box deforms. Does it make a difference, if the box is open or closed?

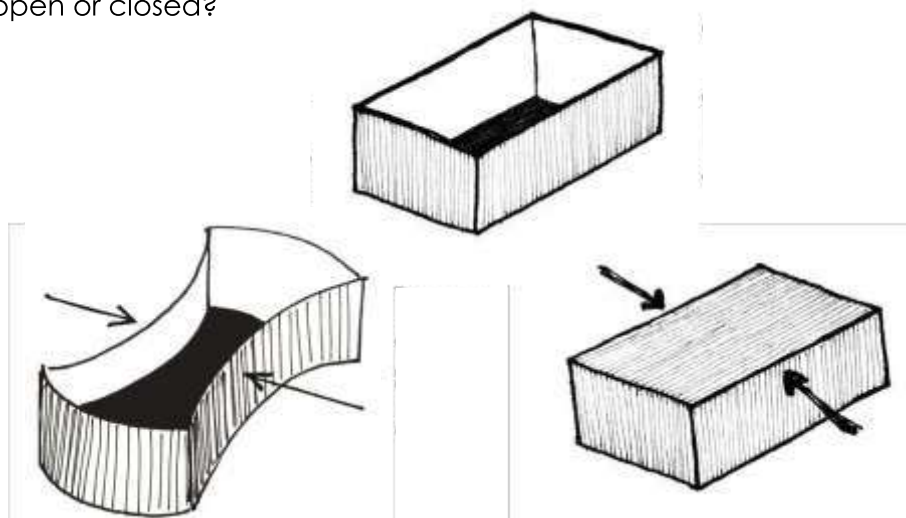

Box Action (Load Bearing Construction)

A house is like a cardboard box. If its walls, roof and foundation are tied together well, it will not fall apart or deform, even if shaken by an earthquake or forced by a cyclone.

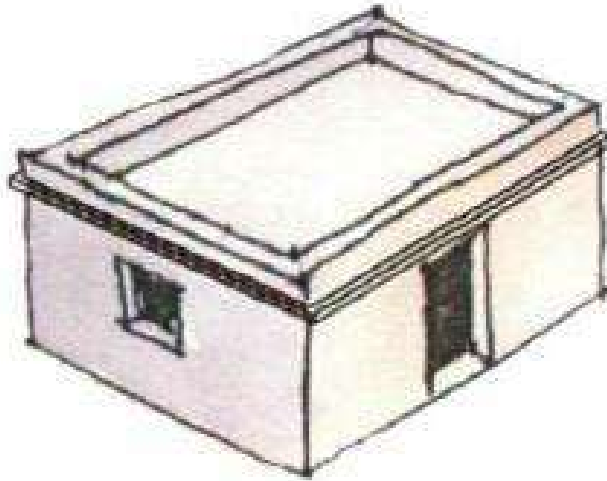

Box Action (Load Bearing Construction)

When a horizontal force is applied to a masonry house, some walls will be in the direction of the force and others perpendicular to it. Walls in the direction of the force are stronger, and those perpendicular to the force are weaker.

Weaker walls will transfer their loads to the walls in the stronger direction and **this load transfer happens at corners, through bands and through the roof.**

If a house acts like a box, it has a better chance of transferring the loads more easily to the ground, and therefore sustains less damage.

Bands

Have you noticed that the top of a bucket has a thick ring around it? Why is this so?



Bands

The bucket without a rim behaves similarly to a plastic glass without a rim. It deforms with the slightest of pressure on its edges.

In houses, the bands in walls are like the rim of a bucket and the rim on the plastic glass. They keep the building together to ensure that it acts as one box.



Bands

Bands are added to houses to ensure that the walls stay together, and transfer the loads from one wall to the adjoining perpendicular wall, so the loads can be transferred to the ground more evenly.

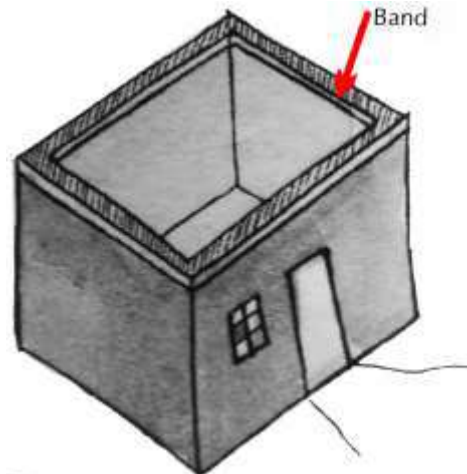

C5 Principles of Hazard Resistant Construction
NDMA Unnati PIC

20

Bands

Here is an example of a house, where bands tie it all together.

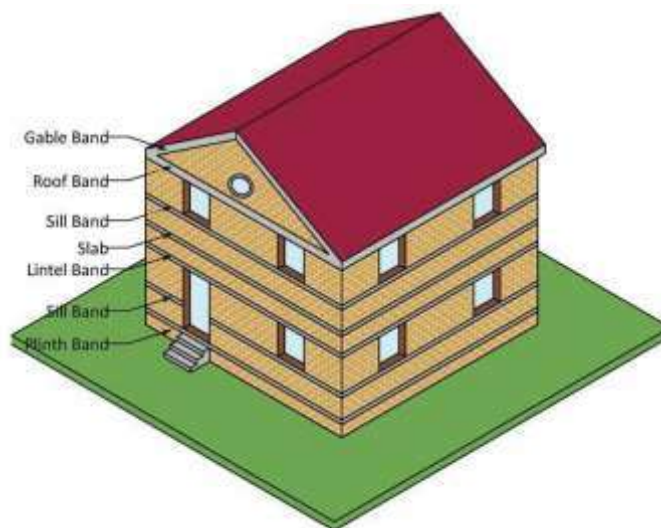

C5 Principles of Hazard Resistant Construction
NDMA Unnati PIC

21

Anchoring

Clothes hanging on a clothesline fly off in strong breeze.

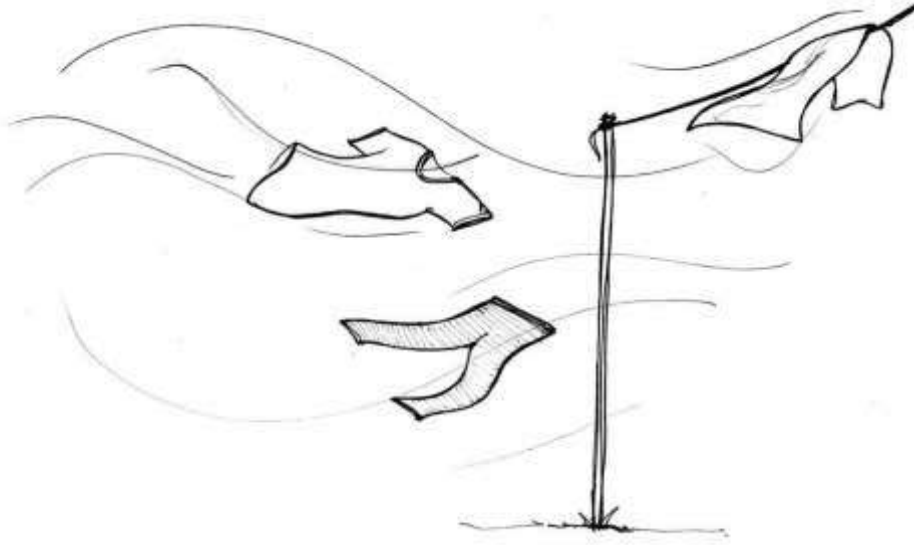

Anchoring

Clothes need to be anchored using clips to ensure they do not fly off in strong breeze.

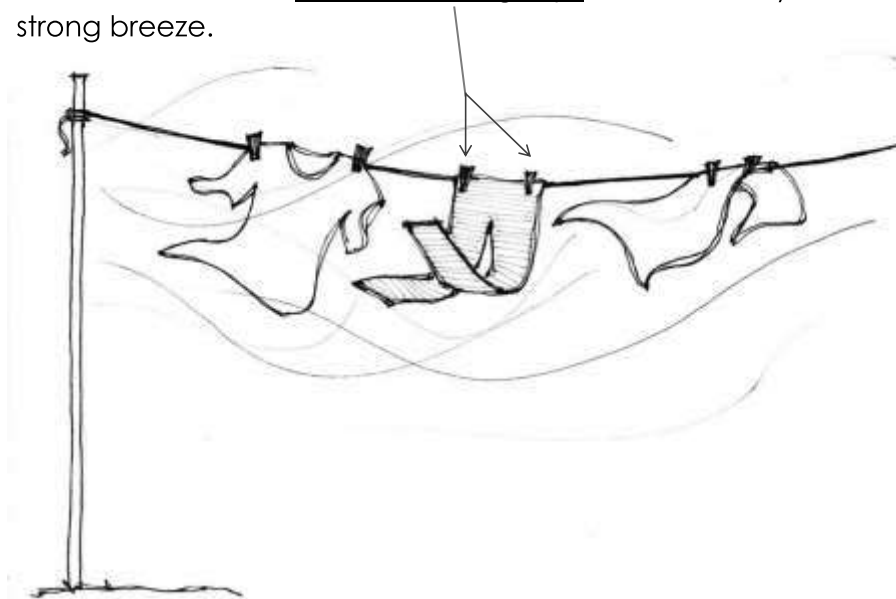

Anchoring

Similarly, when a strong wind blows, the roof may be uplifted and may be pulled away along with any other element of the house which is loosely attached.

If we keep a coaster on a glass and shake the glass, the coaster may fall off, unless it is properly anchored. Similarly, when there is a strong wind force acting on a side of the house, it may cause elements that are not anchored properly to fly off.



Anchoring

To ensure the entire house is well anchored, the joinery between plinth and walls, between adjoining walls, walls and roof, and between different roof elements must be secured safely to ensure that they do not get damaged during an earthquake or a cyclone.

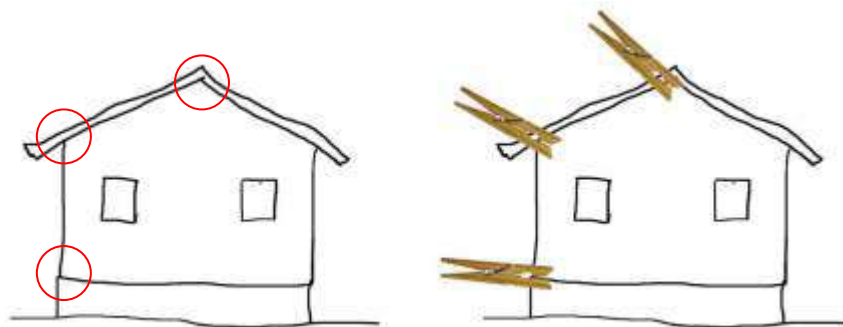

3. Elasticity

It is the property of a material to be able to come back to its original shape.

- a) Materials, like **timber, bamboo and steel**, are more elastic than materials, like brick, concrete blocks and earthen materials.
- b) Homes made of elastic materials may be able to come back to original positions more easily.
- c) For practical purposes, these cannot be the only materials used in the building and therefore it becomes important to design buildings well to ensure that elastic materials are at the right place and in the right quantity.
- d) Also materials that are elastic, but which break suddenly when their limit of elasticity is crossed, need to be used carefully in construction.

A house should be able to come back to its original position after a hazard.

Think about a tree. Typically it stands firmly on the ground. When the harsh winds put horizontal pressure on a tree, it moves with the wind. It is flexible enough to not break and bend with the wind. When the wind stops blowing it returns to its original position.



4. Ductility

It is the ability of a material to deform under stress instead of breaking.



Let's compare this chalk and a steel pin. What would happen, if I apply a (horizontal) force on the chalk and on the steel pin?



The chalk would break into two or more pieces, while the steel pin would bend. This property of materials (like steel) to bend with damage but without breaking is called **ductility**.

4. Ductility

1. This property helps houses, which need to be reinforced to not break suddenly during a hazard.
2. When a horizontal force is applied to a column that typically takes vertical forces, the brittle material may break first. In case of a typical column, it is the concrete.
If a column in a house has not reinforced appropriately, it may immediately break and cause loss of life and property.
3. On the other hand, an appropriately reinforced column, will first fail due to reinforcement (usually steel) and so will bend and deform, but it will not break suddenly. Steel has the ability to stretch large amounts before it breaks. This will give enough warning to escape or repair the building.



Caution: Over reinforcement should be avoided, since concrete will fail first in such case.

Are these materials Ductile or Brittle?

Ductile

Bamboo



Wood



Steel bars



Plastic pipe



Brittle

Stone



Concrete



4. Ductility

Here is a RC roof under-construction, reinforced with steel bars.



Does it mean that putting more steel reinforcement is good?



Over-reinforced beam

When the longitudinal reinforcement is more and transverse reinforcement is less, then the concrete fails first. It results in sudden collapse of the beam.



Under-reinforced beam

When the longitudinal reinforcement is less and transverse reinforcement is more, the reinforcement fails first. Due to ductility of steel, the collapse is gradual.

5. Bracing

In-plane deformation for frame construction.

What would happen if a horizontal force is applied to an unbraced frame?

During an earthquake, horizontal forces induced deform unbraced frames. To reduce damage, cross bracings are added to frames.



Imagine a table in your home is not stable and shakes every time you put force on it from one side. How will you stabilize it?

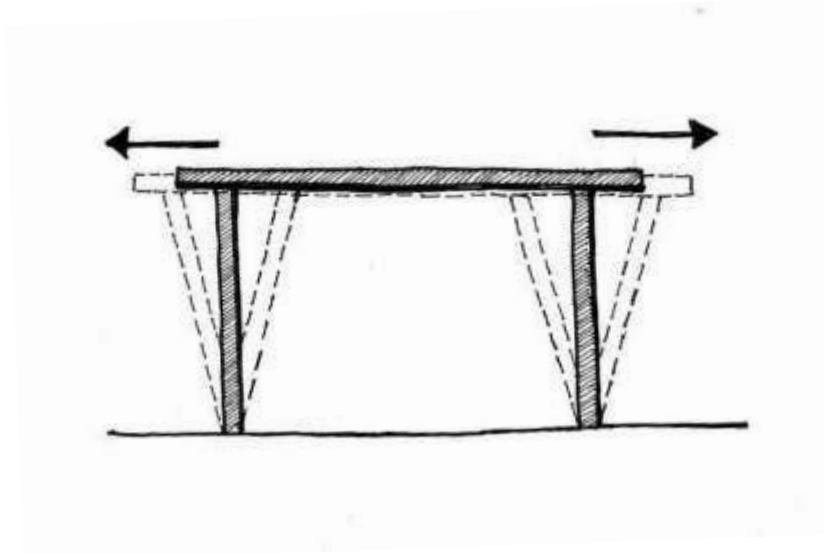

The table can be braced using wooden members to make it stable.

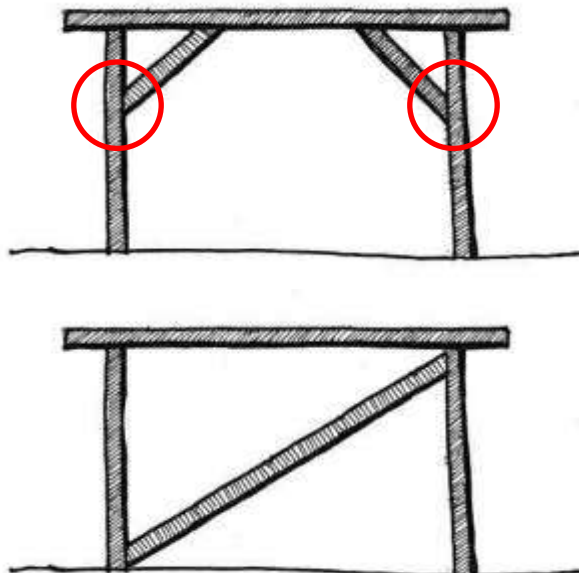

Using the same principle of triangulation, RC frames can be strengthened as shown above.

Bracing: In-plane Deformation of a Frame

Braced frames use **trussing** to resist sideways forces on buildings.

Trussing, or triangulation, is formed by inserting diagonal structural members into rectangular areas of a structural frame.

It helps stabilise the frame against sideways forces from earthquakes and strong winds.

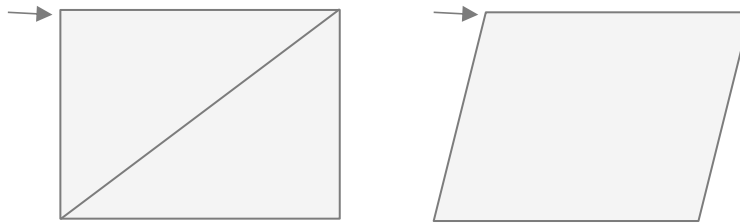

Bracing in frame construction

Here is an example of a building with it's frame braced.



Wall

Roof

6. Protection from Water and Wind

Plinth height: To protect the house from floods, the plinth height must be designed **150mm higher than the highest annual flood level of the last 50 years.**

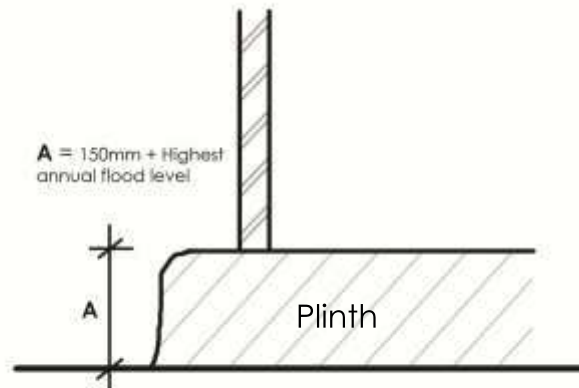

6. Protection from Water and Wind

Plinth Protection:

Why do we need to do this?

Plinth can get damaged because of scouring due to floods or tsunami.

How can we achieve this?

6. Protection from Water and Wind

Plinth Protection:

To achieve this,

1. Extended plinths (Baithak, Ofla, Verandah) can be used.



6. Protection from Water and Wind

Plinth Protection

To achieve this,

2. Protect the plinth edge by providing brick or stone lining.

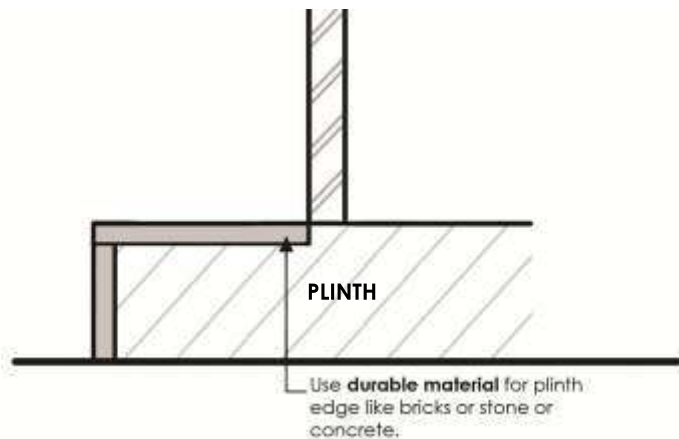

6. Protection from Water and Wind

Roof Protection

Why do we need to do this?

Heavy winds can uplift the roof and rainfall, on entering, can damage the structure. Leakage, over time, is a nuisance and can weaken the structure

How can we achieve this?

6. Protection from Water and Wind

Roof Protection

1. The angle of the slope is determined by the amount and intensity of rainfall. If flat roof, at least a minimum slope for drainage must be ensured.

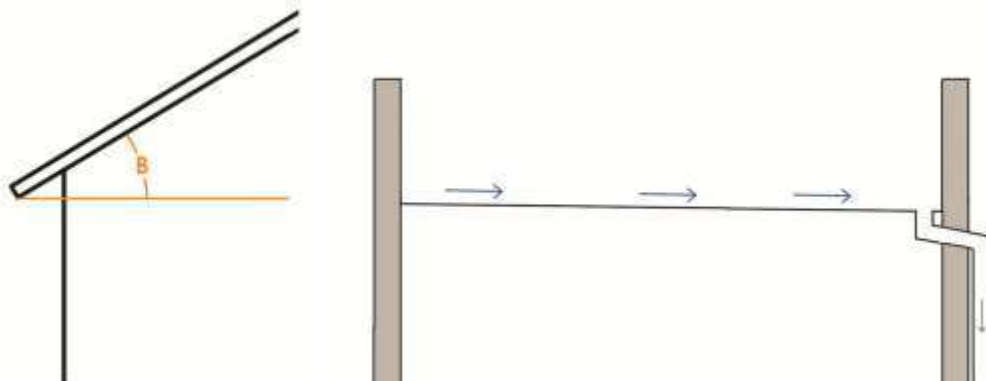

6. Protection from Water and Wind

Roof Protection

2. Joints of the roof must be **strong** and **leak proof**.

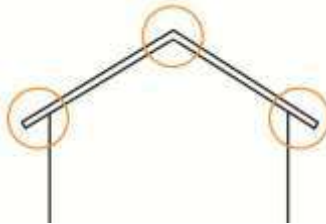

3. Materials used must be **sturdy**, **water resistant** and **durable**.

Discussion

**How these Hazard Resistant Principles are incorporated in houses
in your area?**

Do they work? Are they adequate?

Summary



Earthquake: Use of ductile materials allows the house to get damaged and not collapse. The house needs to come back to its original position. Bracing and bands help transfer loads to the ground more quickly, thus withstanding the shock.



Flood: The house should be above the expected flood level and be strengthened at the base to resist erosion and scouring.



Cyclone: If the roof is heavy and well anchored, it has less chances of being unhinged and flying away.

To resist most hazards, the house must be well sited and anchored properly to ground.

C6

Building Size and Configuration

No. of Slides: 17

Time: 1 hour



National Disaster Management Authority



Unnati

Organisation for Development Education



People in Centre

Expected Outcome

1. Masons develop an understanding of the optimal sizes, configurations, mass of the house, and performance during hazards.

1. Size and Proportions of the House: Length, Height, Depth



Buildings with one of their overall sizes much larger or smaller than the other do not perform well during earthquakes, floods or cyclones.

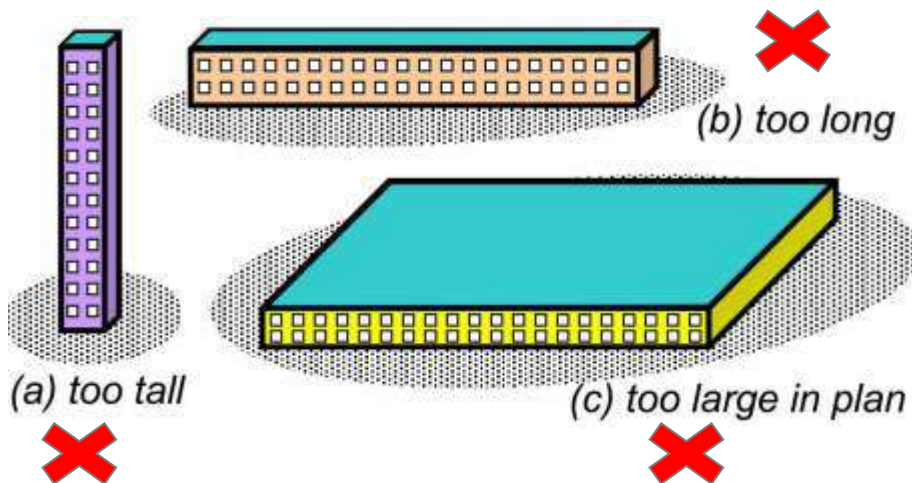

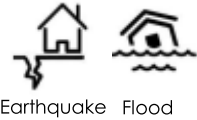

Avoid houses that are too long and those which have its longer dimension greater than 7m.

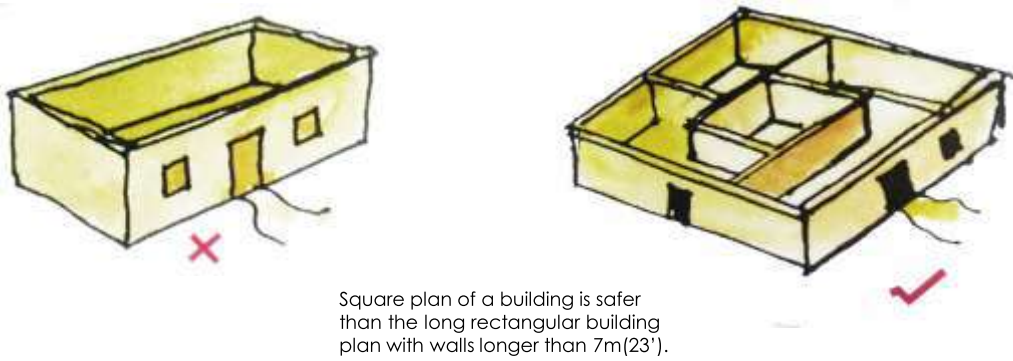

Square plan of a building is safer than the long rectangular building plan with walls longer than 7m(23').

2. Setbacks and Asymmetry

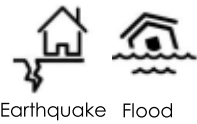

Distribution of mass and (horizontal) lateral load resisting elements across the house must be symmetrically placed. Otherwise, during an earthquake, they will behave differently at different points of the building as the load is not able to flow smoothly and uniformly to the ground.

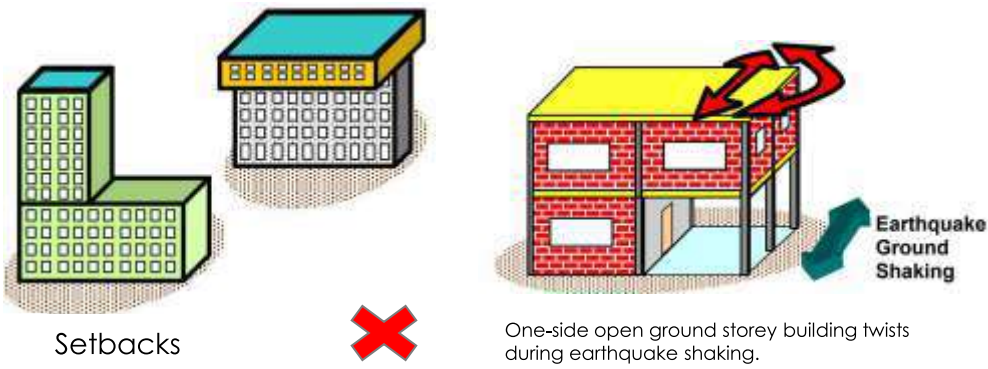

One-side open ground storey building twists during earthquake shaking.

2. Setbacks and Asymmetry

Two houses should not be built too close to each other.

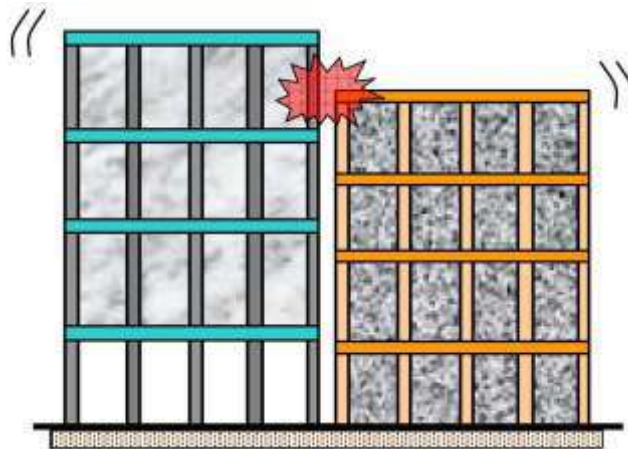

Pounding can occur between adjoining houses due to horizontal vibrations of the two houses

C6 Building Size and Configuration

NDMA

Unnati

PIC

6

3. Shapes of Houses

Simple shapes are preferred.



Complex shapes (like H and L) have corners which are more stressed than the rest of the house, and therefore the house may fail there. Pockets where water and wind can get stuck, are weak points in the house.

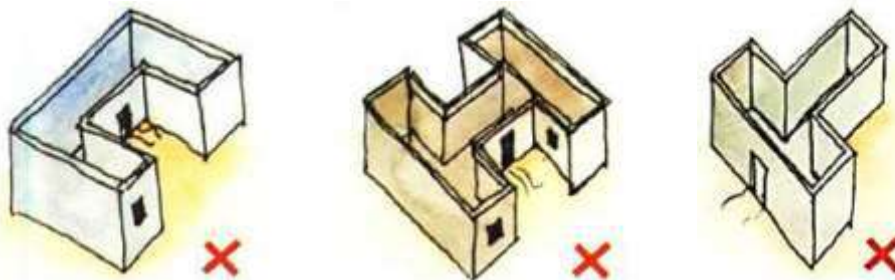

Avoid making buildings with plans having 'C', 'H', 'T', or 'L' shapes in hazard-prone areas.

C6 Building Size and Configuration

NDMA

Unnati

PIC

7

Break complex shapes into simpler shapes.



House with a symmetrical plan is safer than the one with an asymmetrical plan.



Divide the building into a number of symmetrical units, which are well separated.

C6 Building Size and Configuration

NDMA Unnati PIC

8



Simple square, rectangle, circle shapes are preferred because they are symmetrical, and hence more stable. They transfer loads to the ground uniformly.

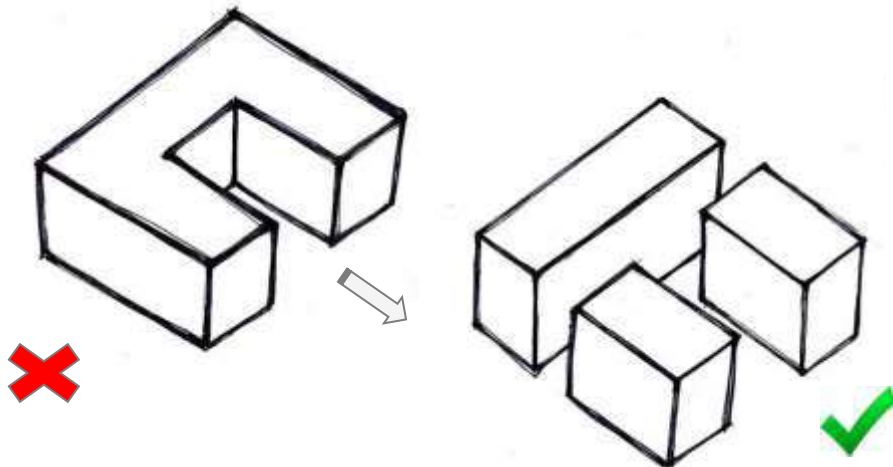

C6 Building Size and Configuration

NDMA Unnati PIC

9

4. Different Storey Heights

lead to the house to not behave uniformly during a hazard.

The house will fail at the junction of the two different kinds of storeys, as those storeys will behave differently compared to the rest of the storeys.

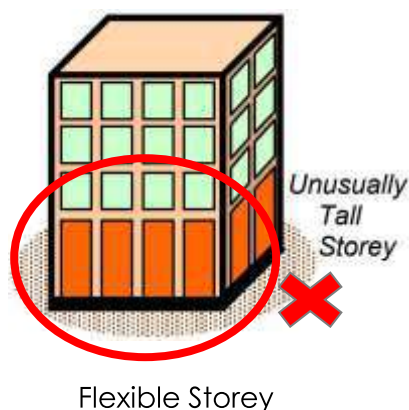

5. Short Column

Damage during hazards

A short column is more vulnerable compared to a fully encased column with infill walls. The full height infill walls make the entire column stiff, and hence resistant. With partial infill walls, the column is free to move over a small height, which can make this shorter column vulnerable.

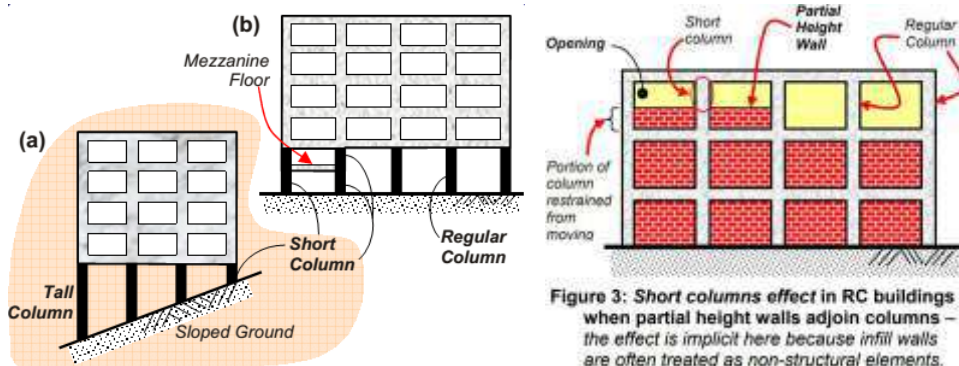



6. Discontinuous Structural Elements do not allow proper transfer of loads to the ground, and thus cause the building to fail at those junctions.

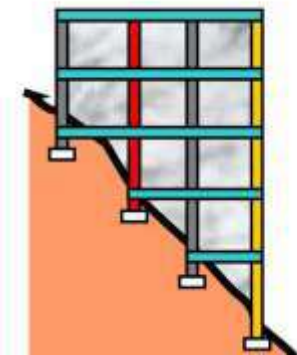

Sloped Ground

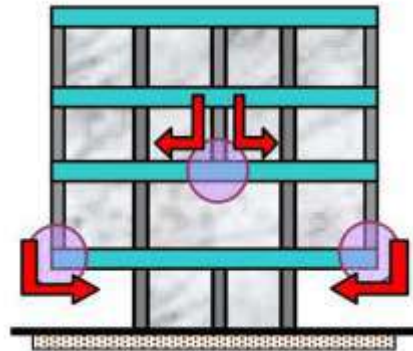

Hanging or Floating Columns

7. Layout of Houses to reduce tunnelling effect

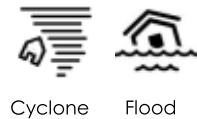

In the two sets of house layouts shown here in plan, in which would the wind move faster?



Set 1

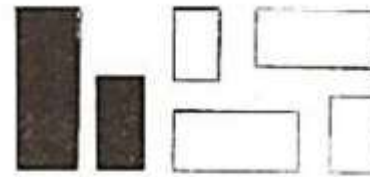

Set 2

7. Layout of Houses to reduce tunnelling effect

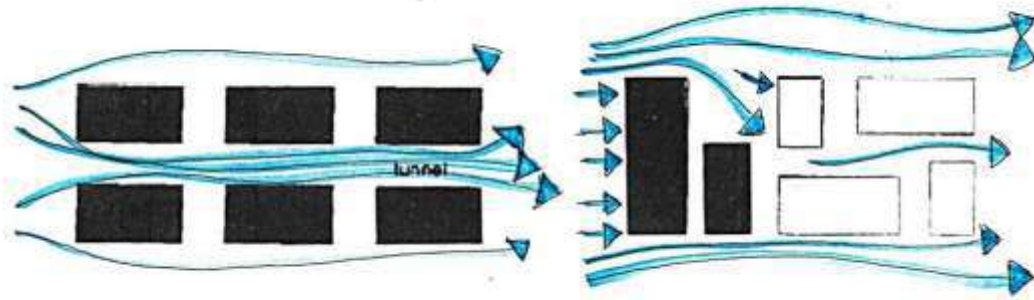
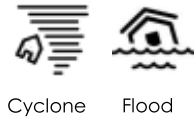

Row planning increases speed of wind and water.

Zig-Zag planning reduces speed of wind and water.

8. Planning for Extensions

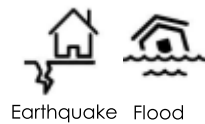

Preferably, **additions to a house should be done as separate buildings** rather than adding to the same building. The new addition will behave as different structure placed next to old building, if not connected properly and therefore their junction would be vulnerable. If the building has to be extended it must be properly connected to ensure proper load transfer during a hazard.

8. Planning for Extensions



Earthquake Flood

1 (Preferable)

Separate the old and the new structure with a considerable gap and construct separate RC bands.

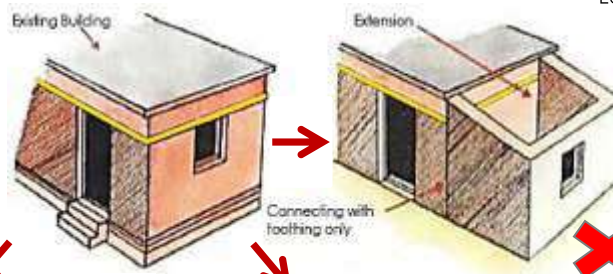
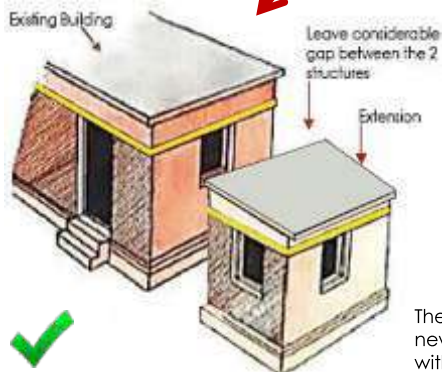

3 Not a good option, since lintel band is not continuous and the junction between the structures is not strengthened.

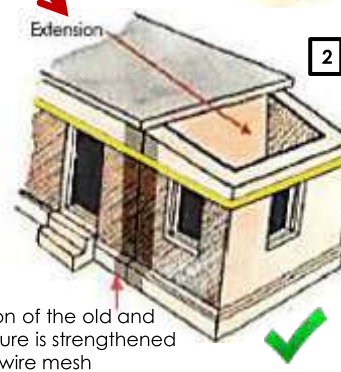

2 If the separation between structures is not possible, strengthen the junction with **Weld Wire Mesh**



C6 Building Size and Configuration

NDMA

Unnati

PIC

16

Summary

1. Simple, symmetric shapes are better.
2. Neither height, length or breadth should be greater unduly in comparison to the other two dimensions.
3. Houses should not be too close to each other.
4. Houses should be symmetric in plan and in elevation.
5. Loads should be transferred to the ground as directly as possible.
6. Houses may be placed in plan in such a way, that they reduce tunnelling effect.
7. Horizontal extensions should ideally be made as separate new structures. If unavoidable, they need to be connected properly so that load can transfer as seamlessly as possible.

C6 Building Size and Configuration

NDMA

Unnati

PIC

17

C7

Importance of Site and Soil conditions

No. of Slides: 37

Time: 1 hour



National Disaster Management Authority



Unnati

Organisation for Development Education



People in Centre

Expected Outcomes

1. Participants know the importance of better locations of houses, through desirable site features.
2. They learn to modify site conditions, where possible, to make it better.
3. They understand soil types and its impact on foundation - stability of houses.

UNDERSTANDING THE SOIL

Site and Soil Conditions should be identified before starting construction

- 1. Location:** Proximity to certain geographical conditions (ridge, cliff edge, sand dunes, mangroves, forests, tree cover, water bodies-river, ocean, ponds)
- 2. Slope:** What is the angle of repose of the soil and what is the angle of the slope?
- 3. Drainage:** How well drained is the slope? Or how does the site and its surroundings drain itself when it rains.
- 4. Soil Type:** What kind of soil is on your site (clayey soil, sandy soil, silty soil, loamy soil)? Are the conditions of soil varying or are they the same on the site and the surroundings? Is there organic matter in the soil?
- 5. Water Table:** How much below the surface is the groundwater level?

C7 Importance of Site and Soil Conditions

NDMA

Unnati

PIC

4

Ideal site and soil conditions:

- 1. Location:** Proximity to certain geographical conditions (ridge, cliff edge, sand dunes, mangroves, forests, tree cover, water bodies-river, ocean, ponds)
 - a) Must not be on a natural water path and floodplains,
 - b) Natural cover,
 - c) Ideally, not too close to water bodies, and
 - d) Ideally, not too close to cliff edge or on an unstable slope.
- 2. Slope:** Gentle
- 3. Drainage:** Well drained soil and surroundings. Not coming in the natural flow of water.
- 4. Soil Type:** Well graded soil, compact, non-expansive
- 5. Water Table:** Best, if water is far below the foundation; it does not cause problems for the stability of the building.

C7 Importance of Site and Soil Conditions

NDMA

Unnati

PIC

5

Why is the type of soil important?

1. Bearing Capacity is the capacity of soil to support the loads applied to the ground.
2. Soil with high bearing capacity is suitable for construction.
3. A soft soil, which is not fully compacted, will have low bearing capacity. To capture the kind of soil and to know whether it is properly compacted, the bearing capacity of the soil should be determined through field tests.

Why should a house be built on hard soil?

1. **Gravity load is being taken by the soil. Soft soil has low bearing capacity, whereas hard soil has high load bearing capacity.**
2. During hazards, sometimes, soil loses its capacity, especially when there is sand and water. Hence the building tends to sink.
3. Sandy soil with water (in times of heavy rainfall, flood or dam breaks during earthquakes) may lose its bearing capacity.

Test to identify Soil Type: Ribbon Test

- Take a handful of soil and moisten it to the point where it will form a ball. Wrap your fingers around the ball, and try to squeeze out a sausage between the thumb and forefinger. Let the sausage bend as you form it, whilst watching to see how far it can be bent before breaking.
- If you cannot form a ball, you have very sandy soil.
- If you can feel larger gritty particles in the ball, you have coarse sand.
- If you can form a ball but a sausage cannot be formed without breaking, you have sandy soil with some clay.

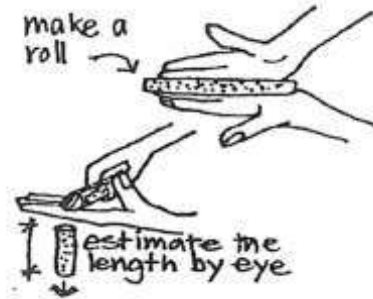

Test to identify Soil Type: Ribbon Test

- If the sausage bends a little, you have a sandy loam.
- If the sausage bends half way around the forefinger, you have loam or silty-loam.
- If the sausage bends more than halfway around your finger, you have clay-loam or sandy-clay.
- If you can form a longer sausage with cracks, you have a clay soil.
- If you can form a longer sausage without cracks, you have fine (or heavy) clay.

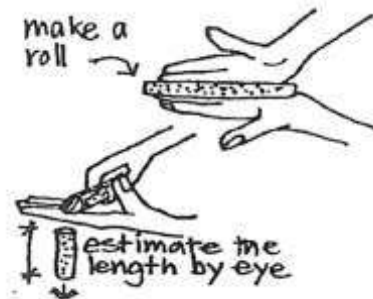

Soil tests

Ideal soil type is well graded, compact and non-expansive without any organic matter.

To check whether a soil is well graded, one must spread out the soil to check whether there are a large variety of sizes of particles in the soil. A mix of different sizes of particles in the soil is preferred.

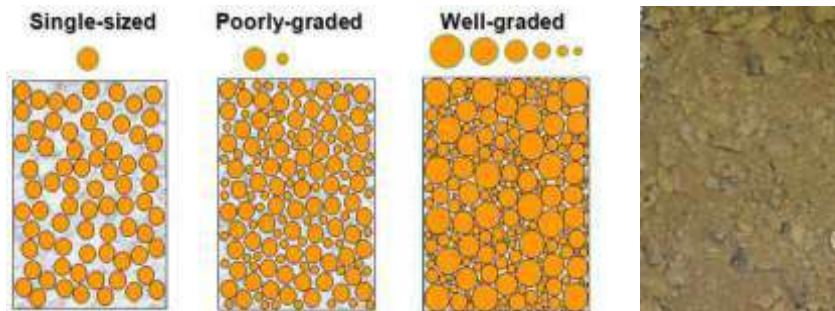

C7 Importance of Site and Soil Conditions
NDMA Unnati PIC

10

Soil tests

Soils that are compacted naturally, usually have their voids properly filled up. Such sites are good for house construction as they have compacted slowly over centuries.

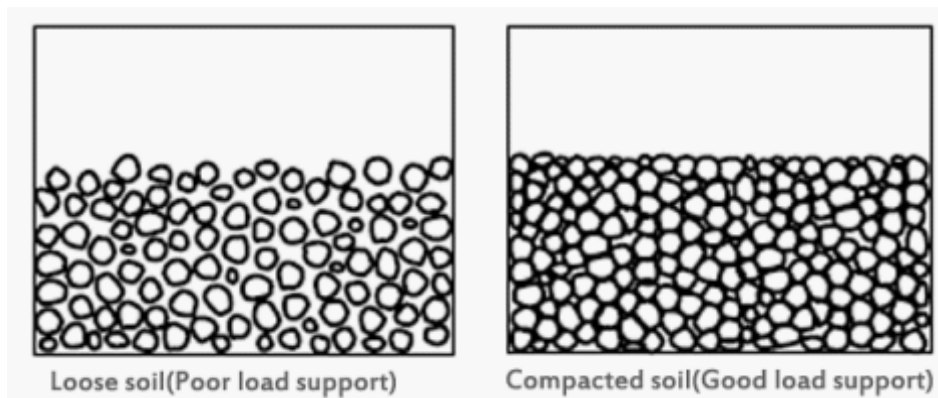

C7 Importance of Site and Soil Conditions
NDMA Unnati PIC

11

Identifying Soft and Hard Grounds



1. Remove top 150mm of soil, and all the filled in soil so that natural soil is exposed.
2. Take a crowbar of approximately 1.5m length and about 4.5 kg weight.
3. Hold it vertically with its sharp point towards the ground, about 600 mm above the ground, and drop the bar.
4. Ensure the bar falls vertically on the ground.
5. Based on the penetration of the bottom end, determine if soil is hard or soft.



Components of Soil

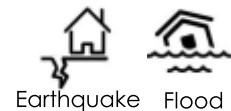

The soil is made up the following particles in different proportions.

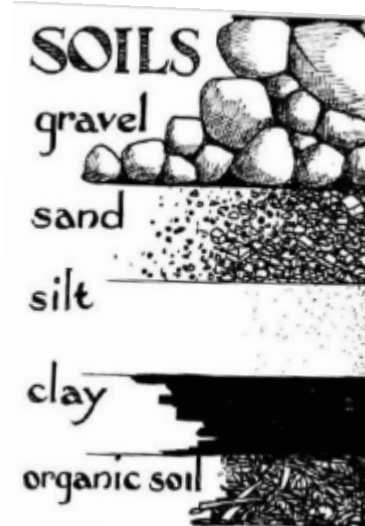

Components of Soil

Soils have 3 basic ingredients.



Sand

It is dry and gritty to the touch and does not hold moisture because of the large openings, but drains easily. When compacted and moist, it holds together fairly well.



Clay

It is made up of tiny particles, so it stores water well, but because of its tight grasp on water, it expands greatly when moist and shrinks significantly when dry.



Silt

Silt can be smooth to the touch and retains water longer because of its smaller particles. But, it is cold and drains poorly.

Components of Soil

Soils normally found in nature have different proportions of sand, silt and clay



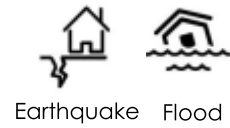

LIQUEFACTION & SINKING during Earthquakes and Floods

Liquefaction is a phenomenon in which the strength and stiffness of a soil is reduced by earthquake shaking or other rapid loading.

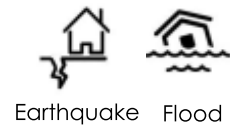
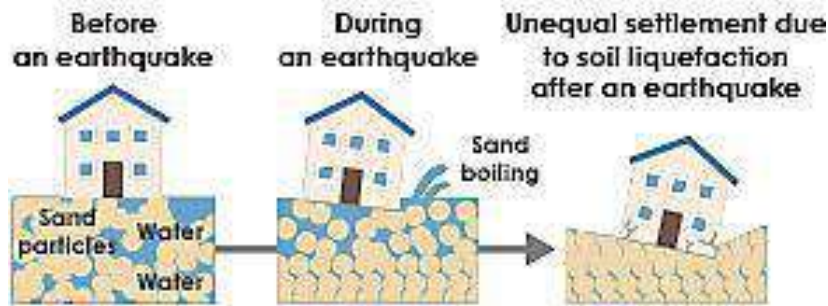

LIQUEFACTION

The sand-water mixture loses capacity to hold the weight of the building above it, and hence the house sinks.

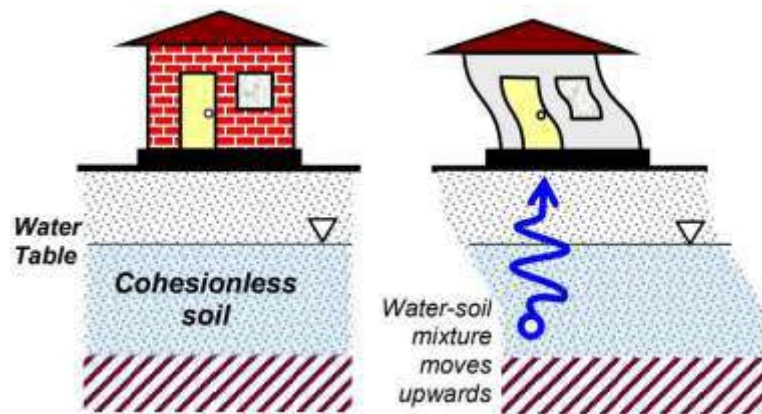

LIQUEFACTION

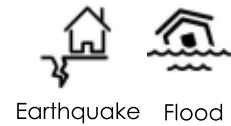

The sand-water mixture loses capacity to hold the weight of the building above it, and hence the house sinks.

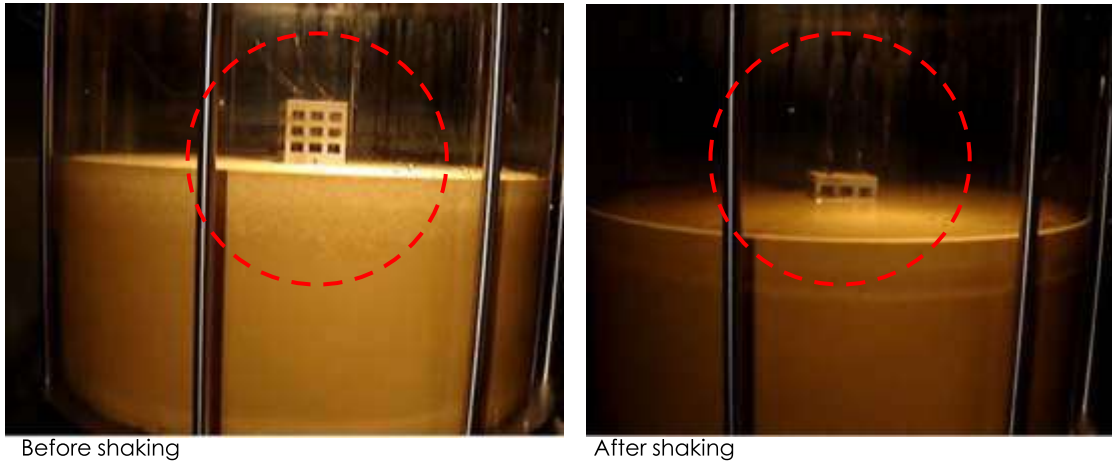

Before shaking

After shaking

What should be done if there is a risk of liquefaction?

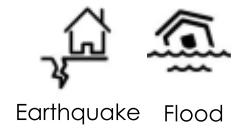

1. Learn about the geological and earthquake history of the area
 - a) Has liquefaction occurred before?
 - b) How far below is the ground water table?
 - c) Are there existing water bodies close by?
2. In case these questions report danger of loose soil or historical examples of liquefaction having occurred in the area of the site of the house, a special foundation will have to be made.

An appropriate pile foundation or a raft foundation will have to be designed by an engineer. This can become expensive, In such cases, the site is unsuitable for housing.



What happens when the soil around the foundation gets washed out because of a flood or tsunami?

The foundation is exposed and weakened which may cause the house to collapse and fall into the pit created due to the scouring of the foundation. We need to ensure the foundations are built on strong ground, so that even if the top layer of soil is washed out, the house continues to stand.



C7 Importance of Site and Soil Conditions
NDMA Unnati PIC

20

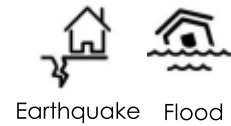

DO NOT BUILD in saline soil

Salt degrades all materials and so they lose their strength overtime. One can check for salt in the soil by tasting it.



Source:
<http://www.fao.org/docrep/006/x8234e/x8234e00.htm#Contents>

C7 Importance of Site and Soil Conditions
NDMA Unnati PIC

21

Building on a site with hard ground



1. If the soil is a mix of rocks and earth, the loose rocks need to be removed, and foundation can be made only on the virgin soil.
2. In case the entire ground is stone, it is possible to anchor the house directly on the rock. It must be ensured that the rock is completely stable.
3. Foundation depth can be minimum 6" in case of rock.

HOW TO BUILD ACCORDING TO SITE

To keep in mind while planning your house

1. Will a hazard affect all the areas in the village equally?

This will help to start thinking about the different conditions of sites in your village, related to geographical and other conditions. It will help to identify the particularly vulnerable parts of your village and ensure that your site does not fall in those areas.

2. Is the house you are building coming in the way of natural flow of drainage of water?

How does the rainwater in the surroundings of your site drain out? If the house is in the way of the natural flow it will cause problems for the house. The best way to deal with this is to allow for a path for the water to pass through your site, and thereby not affecting the house.

To keep in mind while planning your house

3. Is there a presence of natural barriers on your site against cyclone or floods?

4. What is the soil type on your site? Type of soil present on site will affect the foundation type. Salt content of the soil must be checked.

5. What is the terrain of your site? Low lying areas become catchments during monsoons and must be avoided.

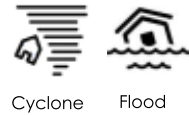

A. Location of Site

1. Considering the highest flood level in 50 years and the low lying areas of your region, decide on a site which is preferably on high ground.
2. Choose site behind wind breakers, or away from localised effects of excessive winds.
3. Choose sites away from steep slopes.

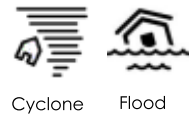

B. Add Wind Breakers around the site

1. A house built on the leeward side of Trees and/or an earthen mound is protected from excessive winds as the trees or earthen mound acts as a wind breaker.
2. High, strong boundary walls act as barriers to wind movement.





C. Angle of Repose and Angle of Soil Slope

If a slope is steeper than the angle of repose of the soil, there is a concern on its stability against a landslide.

Soil Type	Dry	Moist	Wet
Top Soil; Loose	35 - 40		45
Loam; Loose	40 - 45		20 - 25
Peat; Loose		15	45
Clay/Silt; Solid		40 - 50	
Clay/Silt; Firm		17-19	
Clay/Silt; Loose		20 - 25	
Puddle Clay			15-19
Silt		19	
Sandy Clay		15	
Sand; Compact		35 - 40	
Sand; Loose	30 - 35		25
Sandy Gravel; Compact		40 - 45	
Sandy Gravel; Loose		35 - 45	
Sandy Gravel; Natural		25 - 30	
Gravel; Medium Coarse	25 - 30		25 - 30
Shingle; Loose		40	
Shale; Hard		19 - 22	
Broken Rock	35		45



D. Identify Unstable Slopes around the Site

Landslide

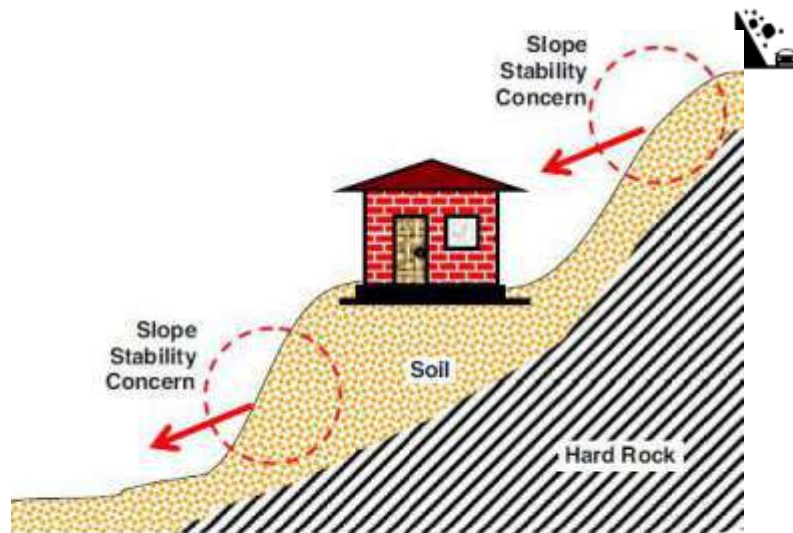

Unstable hill slopes – landslides are major concerns in hilly areas



E. Build Retaining Walls when cutting Slopes

Construct building at least 1m away from top of slope and 1m away from the cut. Also, construct retaining wall to support very steep cut slope, before building the house.



C7 Importance of Site and Soil Conditions

NDMA

Unnati

PIC

30

F. Building near water-body



Tsunami



Cyclone



Flood

1. Build far away from the inundation lines of the water body.
2. Build higher than the 50 year-high flood level of the region.

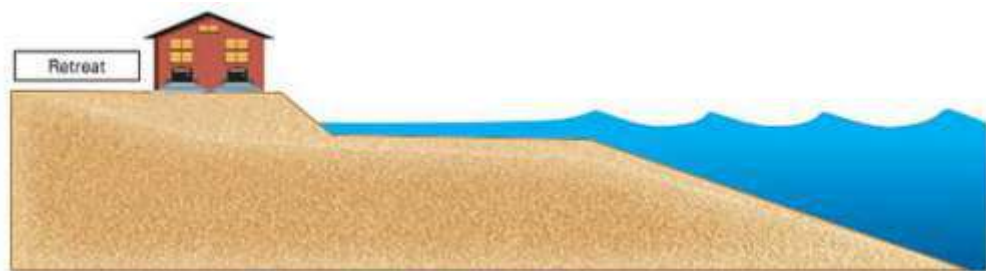

C7 Importance of Site and Soil Conditions

NDMA

Unnati

PIC

31

F. Building near water-body



Tsunami



Cyclone



Flood

For added protection, mangroves can be planted to absorb the impact of the waves and water between the house and the waters.

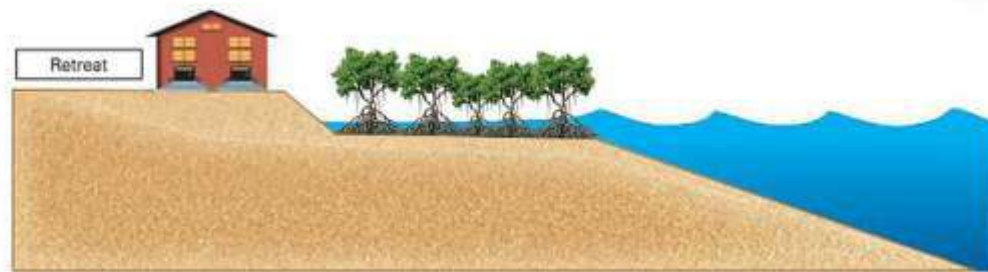

C7 Importance of Site and Soil Conditions
NDMA Unnati PIC

32

What can be done, if site is less than ideal?

Let's make a list of possible solutions

33

177

Measures when Soil and Site conditions are difficult

1. **Low Bearing Capacity:** Soil with a low bearing capacity is unfit for house construction. But, if such construction cannot be avoided, the following techniques (though expensive) can be used with the concurrence of a competent Civil Engineer:
 - a) Pile foundation,
 - b) Wider footing,
 - c) Digging deep to get stable ground for the foundation, and
 - d) Build a lighter house to reduce load.

2. High Water Table: Excessive water renders the area unfit for house construction. But, if such construction cannot be avoided, the following techniques can be used:

- a) Raft foundation (with consultation of an engineer)
- b) Pile foundation

3. Expansive and Clayey Soil: It is best to avoid construction on such soil; it expands and contracts depending on moisture in the soil, and renders the foundation unstable, e.g., Black cotton soil. But, if construction cannot be avoided, the following techniques can be used in consultation with an engineer:

- Raft foundation,
- Pile foundation,
- Digging deep to get stable ground for the foundation, and
- Strip foundations with reinforcement.

4. Foundation Depths

How deep are the foundations in your region?

Thumb rules:

- a) For light weight single storey house, 600mm is the minimum depth required
- b) Rocky ground needs at least 150mm deep foundations
- c) Special soil conditions may need 600-700 mm deep foundations

Summary

We discussed the importance of siting the house in the best possible way with respect to resilience against all hazards.

1. For resilience against the effects of an **earthquake**, the mason should check the type of soil, its hardness, its evenness in composition, possibilities of liquefaction, its expansive nature and whether there are chances of settlement. This will help choose a site with ideal soil type or get help of an expert to design an appropriate foundation for a site, which is not ideal.
2. For resilience against a **landslide**, the slope of the site should be checked against the angle of repose of the site to check whether there is a chance of it being unstable. Also, the slope must be well drained to ensure that the water doesn't create problems to the stability of the slope.

3. For resilience against a **tsunami**, siting the building at a high place such that the water does not reach becomes critical.
4. For resilience against a **cyclone**, the house may be built on the leeward side of trees, hill/earthen mound or other barrier to protect against excessive winds.
5. For resilience against **floods**, the plinth must be made at least 15 cm higher than the expected high flood level, which is something that must be decided based on frequency and intensity of floods in the region, and 50-year high flood level, and make a choice based on the number of days of high floods and the cost of construction.

C8

Hazard Resistant Features Foundation and Plinth

No. of Slides: 41

Time: 1 hour



National Disaster Management Authority



Unnati

Organisation for Development Education



People in Centre

Expected Outcomes

1. Participants understand importance of foundations in hazard resistant construction.
2. They are able to select appropriate foundation for local conditions.

How is the foundation made in your region?

- Q1. What are the different materials and types of foundations that are used in houses?
- Q2. How deep and wide is the foundation built:
- a) For a single storey house?
 - b) For a double storey house?
- Q3. Is the decision about depth and width of foundation dependent on soil type, budget, number of storeys and type of roof?
- Q4. Considering the hazard this region is prone to and the soil types commonly present, what may happen to the foundation, if hazard strikes?
- Q5. What is the risk involved, when upgradations, modifications or additions are done? For example, when the CGI sheet is replaced with RCC, a single storey house becomes a double storey house.

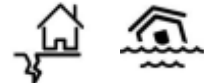

Earthquake Flood

Damages to Foundation and Plinth

1. Uneven Settlement of Soil and Impact on Foundation

If the foundation of the house is built on non-compacted soil or if it is clayey soil which is partially saturated, it may lead to uneven settlement of the building.

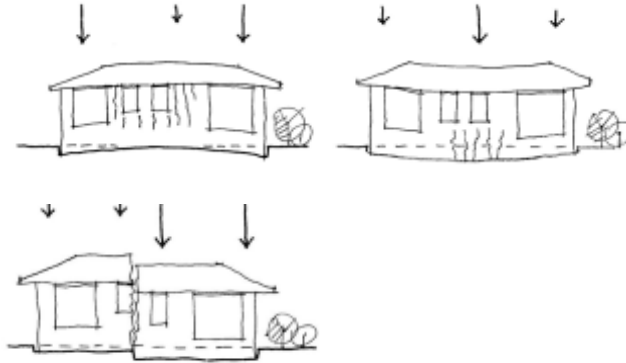

C8 Hazard Resistant Features for Foundation and Plinth

NDMA

Unnati

PIC

4

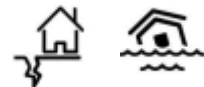

Earthquake Flood

2. Scouring of Foundation and Wall Base

Fast moving water erodes the soil underneath the foundation. This weakens the structure resulting into large holes or cracks or collapse of walls.



C8 Hazard Resistant Features for Foundation and Plinth

NDMA

Unnati

PIC

5

Types of Foundations

1. Strip Foundation

Load bearing walls are supported by continuous foundations that spread out at the base to ensure a wider surface area for the load to transfer to the ground. This type of foundation is called a Strip Foundation. The spreading out of the base ensures stability.

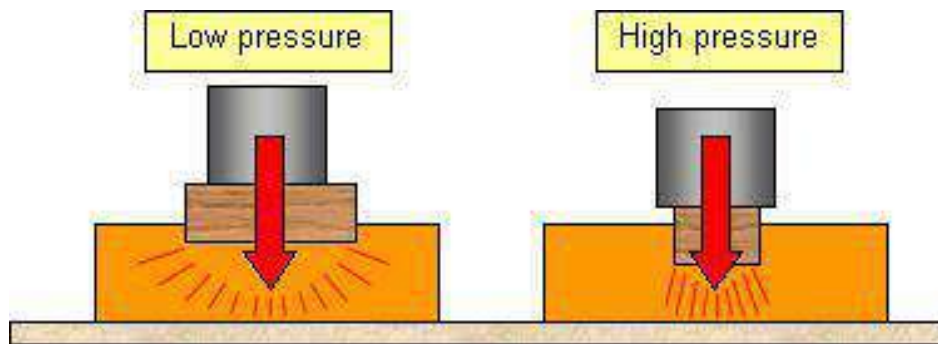

C8 Hazard Resistant Features for Foundation and Plinth
NDMA Unnati PIC

6

Strip Foundation

Imagine piercing a narrow object into the wall versus piercing one with a large base. What happens in the two situations?

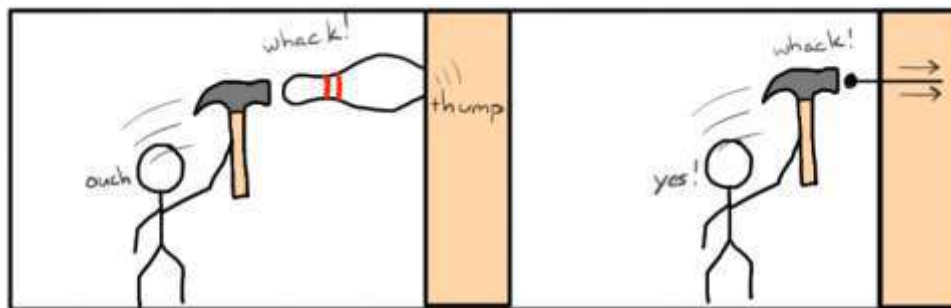

C8 Hazard Resistant Features for Foundation and Plinth
NDMA Unnati PIC

7

Strip Foundation

The base of the strip foundation is always wider at the bottom. If the soil, where you are building, has lower bearing capacity, the foundation should have an even wider base at the bottom.

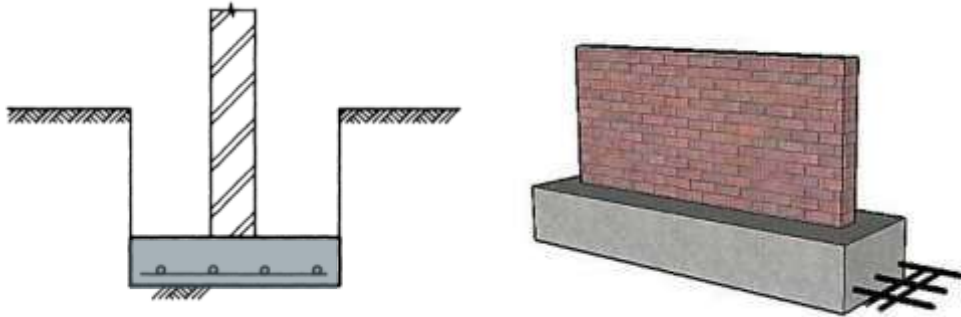

C8 Hazard Resistant Features for Foundation and Plinth
NDMA Unnati PIC

8

2. Stub Foundation

In the stub foundation too, the base is wider and it becomes narrower as it comes up. The stubs need to be provided at all junctions and tied with beam.

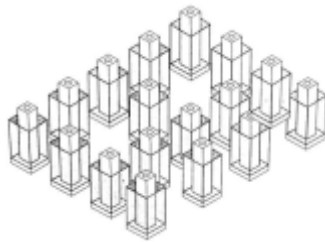

C8 Hazard Resistant Features for Foundation and Plinth
NDMA Unnati PIC

9

The stub foundation has a concrete padding and is made of brick. On top, it is the size of the column itself.



C8 Hazard Resistant Features for Foundation and Plinth
NDMA Unnati PIC

10

Pile Foundation, Raft Foundation and Individual Footing

Special Foundations when the soil type is less than ideal (loose soil, too much clayey and expansive, or with possibility of settlement or liquefaction). **All these foundations need to be designed by an engineer.**

3. Pile Foundation

When the soil is loose and the foundation needs to take a heavy building's load, the foundation is taken down to the bedrock.

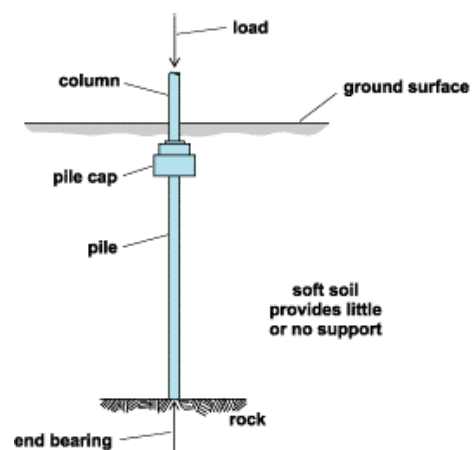

C8 Hazard Resistant Features for Foundation and Plinth
NDMA Unnati PIC

11

4. Raft Foundation

Raft foundation consists of RC slabs of uniform thickness, that cover the entire footprint of the building and support a number of walls and columns.



C8 Hazard Resistant Features for Foundation and Plinth

NDMA

Unnati

PIC

12

5. Individual Footing

When the soil is relatively hard and the RC column needs to take a heavy load, the foundation of the RC column is made as an Individual Footing.



C8 Hazard Resistant Features for Foundation and Plinth

NDMA

Unnati

PIC

13

Foundation Details

1. Founding Depths

How deep are the foundations in your region?

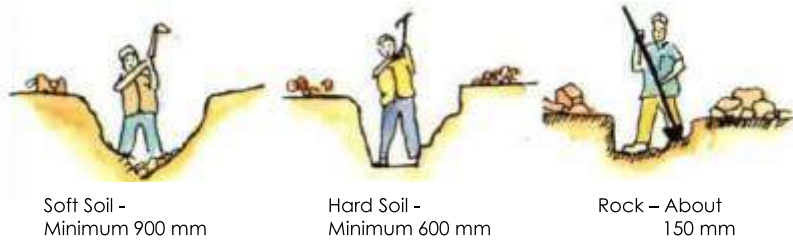

Thumb rules:

1. For light weight single storey structures, 600mm is the minimum depth.
2. Rocky structures allow 150mm deep foundations
3. Special soil conditions as discussed above allow 600-900mm depth.

2. Shape of Trench

1. Where there is hard soil and the foundation is not deeper than 900 mm, a trench with vertical walls can be dug.
2. In any other situation, a trench with a slope will be dug which cannot have a slope more than 2:1.
3. The material dug out of the trench must be kept at least 600 mm away from the trench line.
4. The line out of the centre lines with string must exist until the plinth is complete.

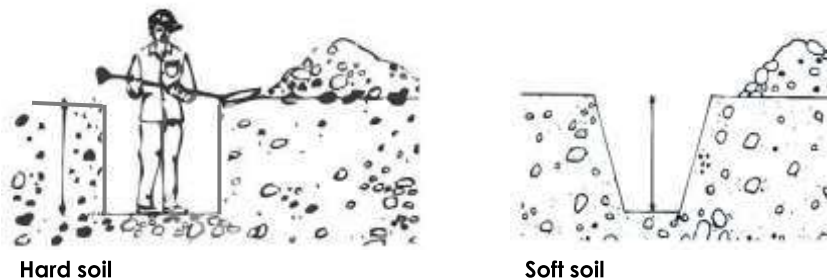

3. Backfilling of Trench

The backfilling of the soil must be done carefully, layer-wise and rammed in with every layer so that the soil is properly compacted.

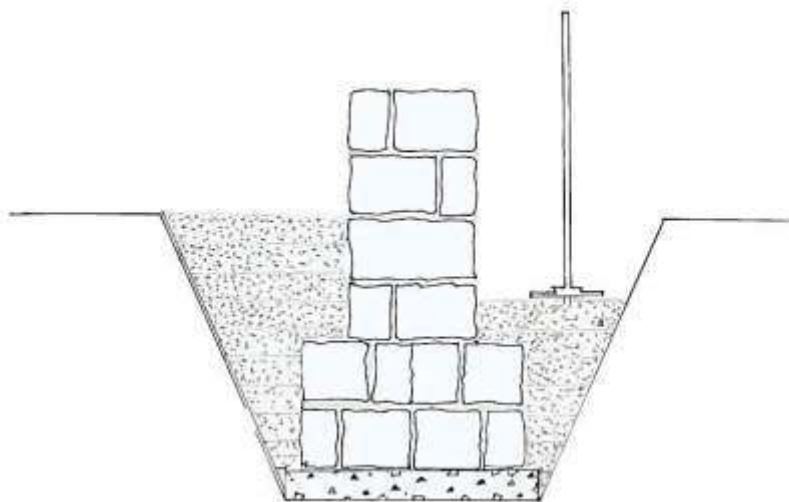

C8 Hazard Resistant Features for Foundation and Plinth
NDMA Unnati PIC

16

4. Rules for Stone Foundation

The following rules for stone masonry must be followed in the foundation:

1. Trench must be dug in a way that the sides of the trench must be as straight as possible.
2. Corner stones must be placed in each course.
3. No voids must be left in masonry.
4. Longer stones/ Through stones should be used.
5. Each course must be levelled well
6. Provide at least one "through stone" at every 1,200mm horizontal distance in the masonry course and at every 600mm height in a staggered manner.



Place each stone flat on its broadest face.



Place long stones at corner in each course with length of stone placed parallel to the length of the wall.

C8 Hazard Resistant Features for Foundation and Plinth
NDMA Unnati PIC

17

7. Rounded stones cannot be used anywhere, including in the foundation.
8. Each course must be properly laid and compacted with sand, following which the trench must be backfilled completely as required with layer-wise compacting.



In the portion of foundation below ground stones must be placed as per rules of masonry.

In the portion of foundation below ground do not use round stones, and do not just dump stones.



C8 Hazard Resistant Features for Foundation and Plinth
NDMA Unnati PIC

5. Through Stones in Foundation

Through stones in foundations must be staggered and used every few courses to bind the wall well.



Both faces must interlock with each other to form one wall. The vertical joint must be broken.



Through Stone



Use RC blocks as through stones, when through stones of the right length are not available.

C8 Hazard Resistant Features for Foundation and Plinth
NDMA Unnati PIC

6. Vertical Reinforcement in Stone Masonry Walls

Vertical reinforcement in the walls must be anchored right from the foundation. The steel bar can be kept in place using a PVC pipe till 3-4 layers of stone masonry is done; then the pipe is removed and the void is filled with concrete, providing cover to the steel.



C8 Hazard Resistant Features for Foundation and Plinth
NDMA Unnati PIC

20

L-junction in English Bond (Foundation)

Vertical Reinforcement in L-Junctions in English bond, where at the base of the Brick Foundation, the wall is 2 brick thick.

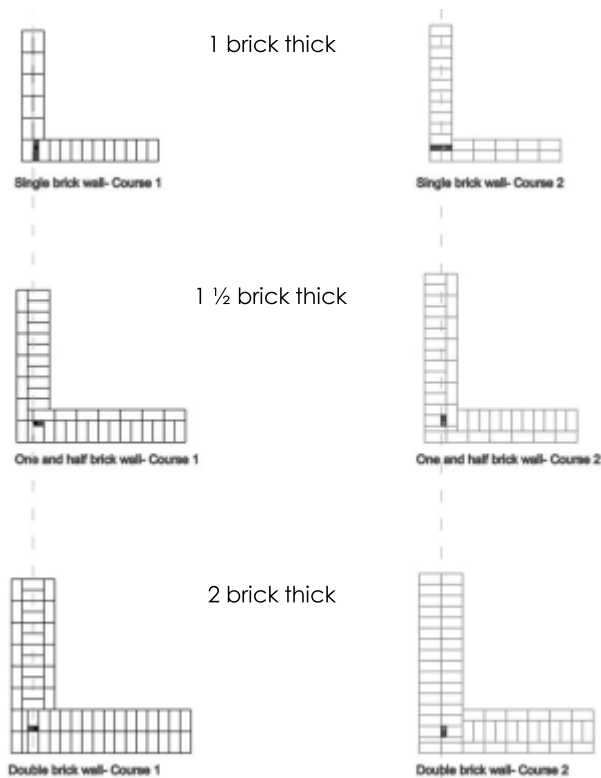

C8 Hazard Resistant Features for Foundation and Plinth
NDMA Unnati PIC

21

L-junction in Flemish Bond (Foundation)

Vertical Reinforcement in L-Junctions in Flemish bond, where at the base of the Brick Foundation, the wall is 2 brick thick.

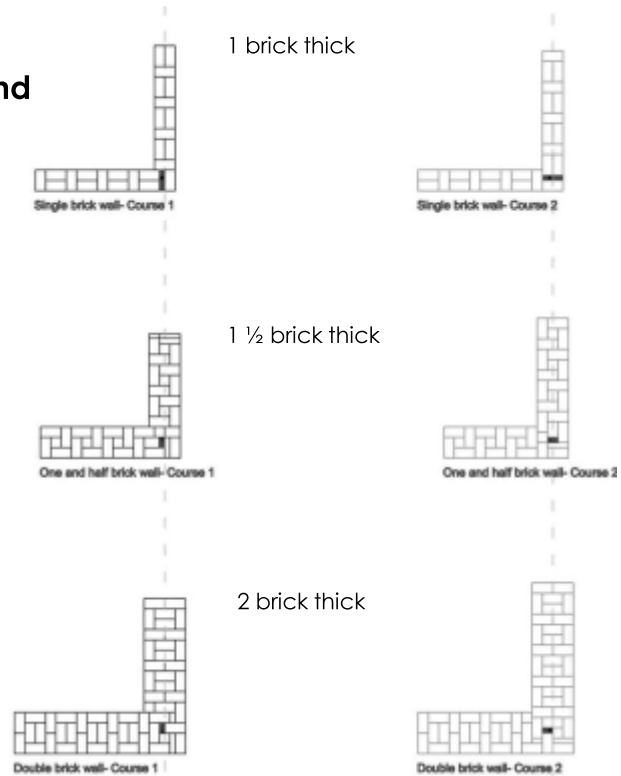

C8 Hazard Resistant Features for Foundation and Plinth
NDMA Unnati PIC

7. Filling Mortar in Joints

All joints must be completely packed using mortar.



C8 Hazard Resistant Features for Foundation and Plinth
NDMA Unnati PIC

8. Foundations in Landslide Prone Areas

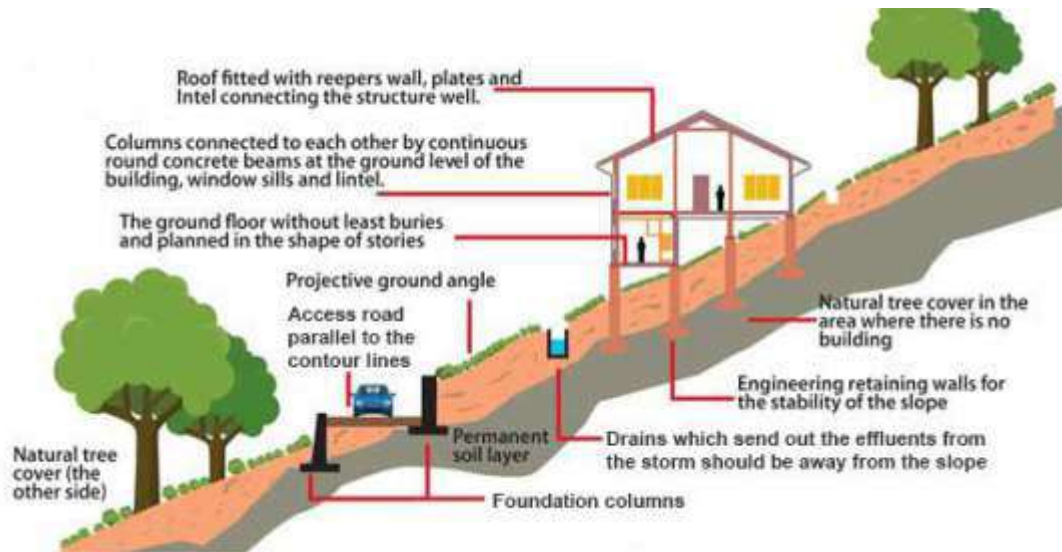

C8 Hazard Resistant Features for Foundation and Plinth

NDMA

Unnati

PIC

24

Plinth

A plinth serves many purposes. It not only protects the base of the house and raises it above the flood levels, but also becomes a social space for people to come together, relax and chat.



C8 Hazard Resistant Features for Foundation and Plinth

NDMA

Unnati

PIC

25

Plinth height must be at least 150 mm higher than the highest annual flood level of the last 50 years.

If the threat perception at any location is more, plinth height should be increased.

Materials that degenerate or lose their strength due to presence of water, should not be used for the plinth.

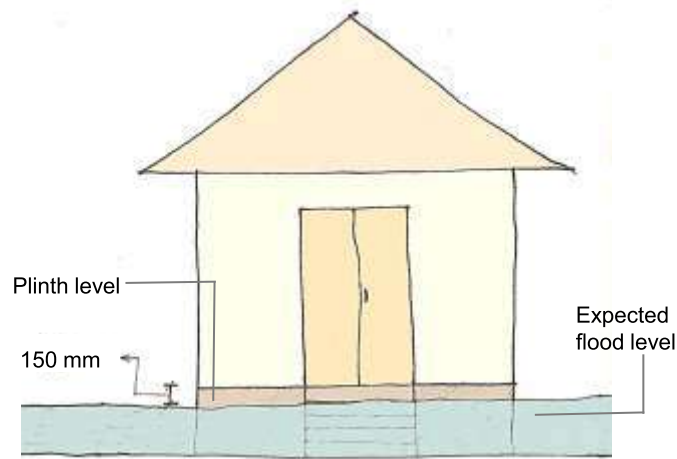

C8 Hazard Resistant Features for Foundation and Plinth
NDMA Unnati PIC

26

Plinth Protection (recollection)

Extended Plinth



Plinth Edge

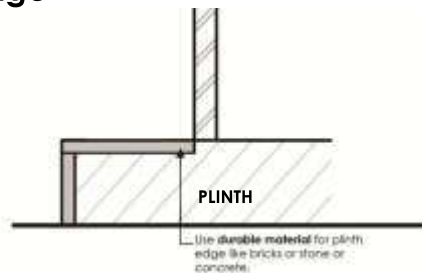

C8 Hazard Resistant Features for Foundation and Plinth
NDMA Unnati PIC

27

Plinth Protection

Plinth should be made with 'cement' or 'mud mortar with cement plaster'. If cement plaster cannot be done, cement pointing is necessary for the protection of the plinth.



C8 Hazard Resistant Features for Foundation and Plinth

NDMA

Unnati

PIC

28

Plinth Details

1. Damp Proof Protection

Damp proofing is done to protect the walls of the house from becoming moist/damp due to capillary action of water. As discussed previously, such action in walls can lead to loss of strength of materials used for wall.

The Damp Proofing Course should be provided at the junction of the plinth and the wall such that water from plinth does not rise into to walls.



C8 Hazard Resistant Features for Foundation and Plinth

NDMA

Unnati

PIC

29

Options for Damp Proof Course

1. Make RC band at plinth level with proper rodding to minimize percolations.



2. Use sheet of polyethylene, plastic or bitumen coated woven polypropylene sacks just at the base of the wall.



C8 Hazard Resistant Features for Foundation and Plinth
NDMA Unnati PIC

30

2. Grade Beam and Plinth Band

The grade beam acts as the damp proof course and avoids water from going up the walls.

Steps to make a concrete DPC:

Step 1:

At the desired height, 2 longitudinal bars are placed 25 mm inside from the wall faces, with cross links in between them at 150mm distance.



C8 Hazard Resistant Features for Foundation and Plinth
NDMA Unnati PIC

31

Step 2:

The longitudinal bars should be at mid height of the required band. This can be done by placing stone pieces under the bars.



Step 3.

The longitudinal bars must be lapped at the L-junction to make a proper joint at the corner. This is the critical joint, which transfers the loads.

Connect bars at wall junction with minimum 450 mm lap length.

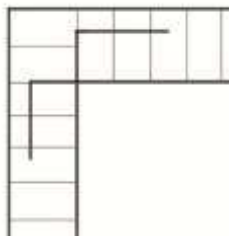

L-Junction Bar arrangement

Step 4

Arrangement of longitudinal bars at T-junction. Here too, the bars need to overlap properly to ensure transfer of loads.

Connect bars at wall junction with minimum 450 mm overlaps.

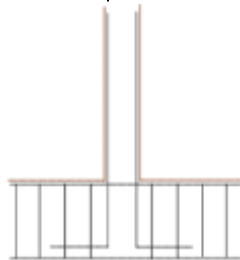

T-Junction Bar arrangement

Step 5.

An L shaped bar with each leg 450mm long is to be tied to the main rebar of the band and the vertical bar together to ensure the entire house is well connected and box-action occurs to transfer the loads to the ground as evenly as possible.

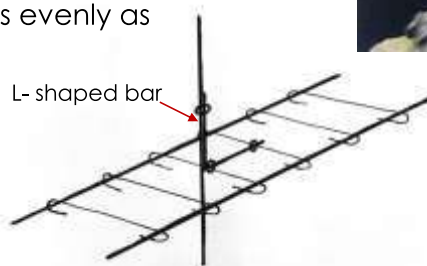

Step 6.

Bar to bar connection must be done with overlap joint of 400 mm for 8mm diameter and 500mm for 10mm diameter.

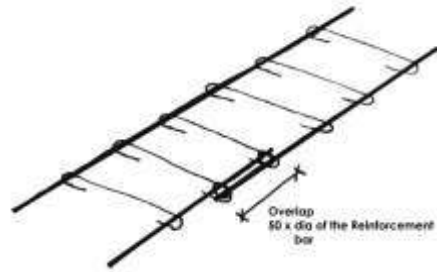

Step 7.

Pour concrete 1:1.5:3 proportion with rodding and cure for 15 days.



Pour concrete of 1:1.5:3 proportion with rodding. Cure band for fifteen days.

3. Alternative Materials to make Plinth Band



Weld mesh encased in 25 mm thick layer of mud mortar.

3. Alternative Materials to make Plinth Band

Timber/Bamboo ladder with proper overlapping at junctions in the wood. Corner joints secured with screws or wooden pegs to ensure proper transfer of loads.

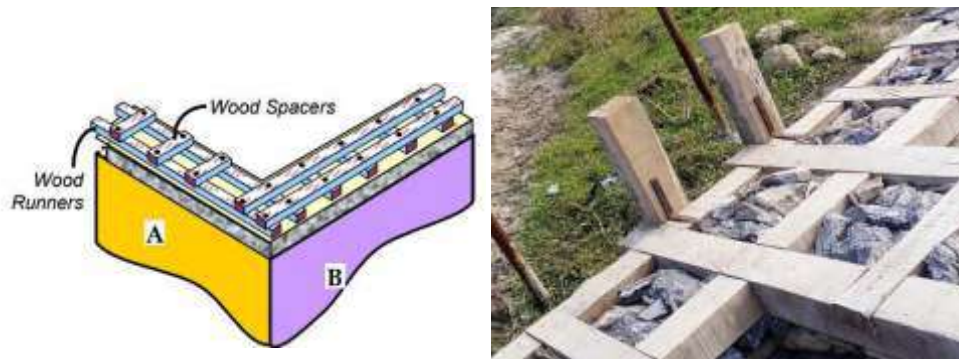

4. Cement Pointing to protect Plinth

Repointing is the process of renewing the **pointing**, which is the external part of mortar joints in masonry construction. Over time, weathering and decay cause voids in the joints between masonry units, usually in bricks, allowing the undesirable entrance of water. This is especially of concern in masonry walls with mud mortar. Repointing the walls is essential periodically over time.



Summary

1. Typical damages to plinths and foundations occur due to uneven settlement of soil, liquefaction, and scouring. When the foundation is damaged, it may be unable to take the load of the house, making the house vulnerable.
2. Depending on the soil type, one can choose between Strip Foundation, Stub Foundation or an Isolated Footing. If the soil is not ideal, i.e. loose, expansive, prone to settlement or liquefaction, pile foundation or raft foundation may be considered and designed with the help of an engineer.
3. We discussed about increasing hazard resistance in foundation and plinth including: (i) Appropriate depth, width and shape of foundation for different conditions, (ii) importance of backfilling and compacting it, (iii) providing vertical reinforcement from the foundations, (iv) following proper stone/brick masonry, (v) Foundations in landslide prone areas, (vi) Plinth protection, (vii) DPC and grade beam and plinth band, and (viii) cement plastering or cement pointing of plinth.

P9

Constructing Sample Foundation and Plinth

No. of Slides: 8
Time: 4 hour 30 min.



National Disaster Management Authority



Unnati
Organisation for Development Education



People in Centre

Expected Outcomes

1. Participants understand critical concepts of siting and details of construction of foundation and plinths.
2. They make observations on the site for hazard resistant construction.
3. They are able to construct good details for hazard resistant foundation and plinths.

Group activity

Make groups of 2 participants each.

Each group will do one of the foundations. They can build the appropriate foundation as per their skillset of approximately 1.2 m length.

They will have one labor to assist them in the construction of the foundation.

Details of Strip Foundation

Strip foundation in Stone (Things to remember)

1. Depth of trench
 2. Compacting the soil
 3. Continuous and corner bonding
 4. Through stones
 5. Sand filling
 6. Settling with water
 7. Anchoring vertical reinforcement
 8. Different ways of filling the joints with mortar or sand properly,
 9. Options of through-stones: (stagger at least $\frac{3}{4}$)
- Can you cast RC as through stones?*

Strip foundation in Brick (Things to remember)

2 courses of each width must be made 2 $\frac{1}{2}$, 2, 1 $\frac{1}{2}$ and 1 brick to make L and T-shaped stepped foundations.

1. Corners
2. Anchoring reinforcement bars
3. Proper filling of joints

Details of Stub Foundation

Stub foundation in Brick

A stub foundation of 2 ½ x 2 ½ brick, until it reaches the top at 1 ½ x 1 ½ brick stub with a vertical reinforcement bar in the center.

Grade Beam and Plinth Band

1. Understanding grade beam and plinth band
2. Junction of vertical reinforcement and the horizontal bands;
Practicing use of different materials for the bands (Timber, weld wire mesh)
3. Damp proofing
4. Simple RC footing: How to make steel cage?
5. Installing vertical reinforcements
6. Horizontal bands with different materials. (timber, bamboo, RC)

The details of bands and beam along with footing and vertical reinforcement must be discussed, such that participants are made aware of the requirements of the wire benders, carpenters and bamboo artisans they work with.

Discussion

1. What did you learn new in this session?
2. What are the common mistakes that you observed?
3. What do you think can be done better in a different way?

C10

Hazard Resistant Features of Walls and Openings

No. of Slides: 58
Time: 3 hours



National Disaster Management Authority



Unnati
Organisation for Development Education



People in Centre

Expected Outcomes

1. Participants are aware of various damages inflicted upon load bearing and in-fill walls during different hazards.
2. They know construction methods of mitigating impact of hazards on walls (principles and design limits).
3. They are aware of safety features and measures for increasing resilience of walls during hazards through construction details (masonry bonds, corner junctions, vertical reinforcements etc.).

Types of Walls

1. Infill Walls: When the load of the roof is transferred to the ground by columns and beams, the walls take only their self-weight. Such walls are known as infill walls.

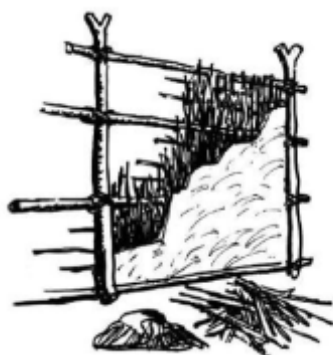

Wattle and daub

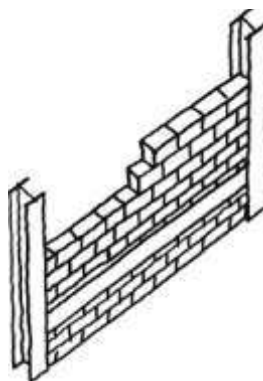

Brick Infill Wall

2. Load Bearing Walls: Walls which transfer the load of the roof or floor above to the ground are known as Load Bearing Walls.

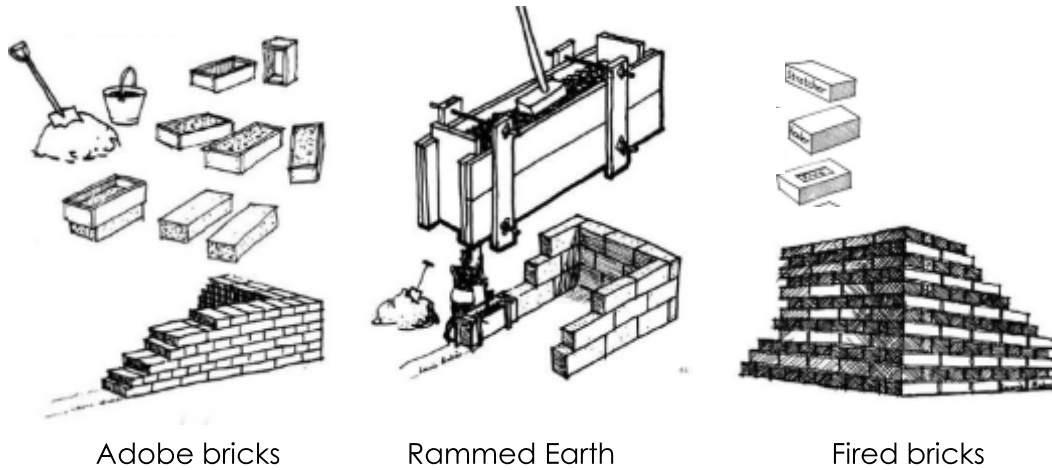

Load Bearing Walls: Load bearing walls with different materials

Hollow Concrete Blocks

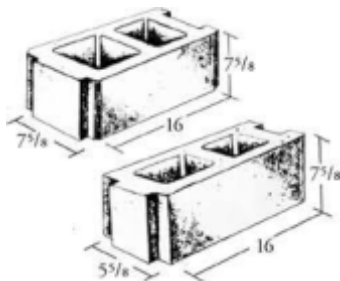

Uncoursed Random Rubble Stone

Random Rubble Stone



Ashlar Stone

3. Confined Masonry Walls: The load is taken by the masonry walls as well as the RC elements. Further, the RC elements confine the units at corners and junctions, strengthening the structure against lateral forces.

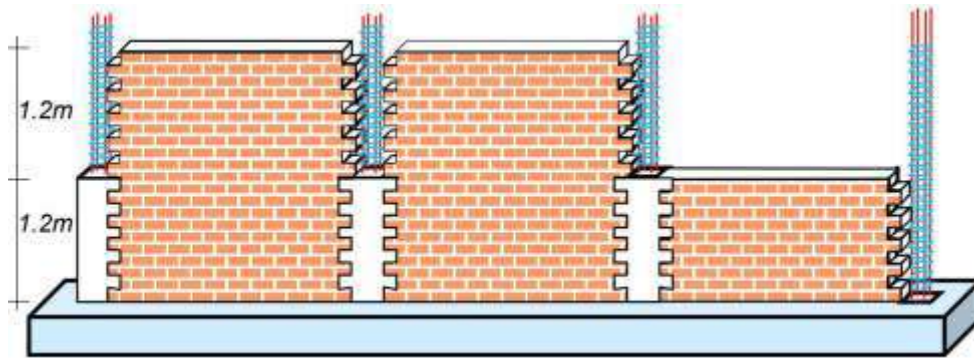

C10 Hazard Resistant Features Of Walls and Openings
NDMA Unnati PIC

6

The RC corners as well as the brick masonry is constructed together and integrated well with each other.

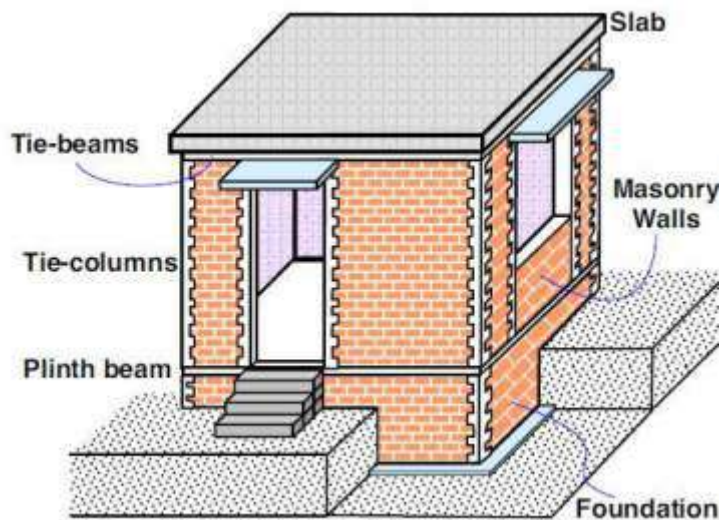

C10 Hazard Resistant Features Of Walls and Openings
NDMA Unnati PIC

7

Difference between Confined Masonry and RC Frames with Infill Walls

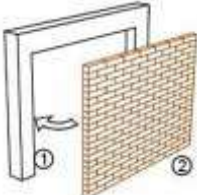
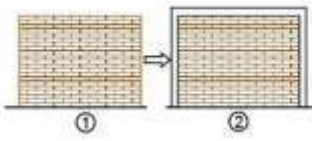
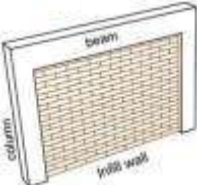
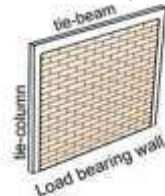
	RC Frame and Infill	Confined Masonry
Construction Sequence	<p>First RC frame is made, later the brick infill wall is made.</p> 	<p>First the brick wall is made and later the confining RC elements are added.</p> 
Size of Elements	<p>The beam and column of the RC frame are relatively larger.</p> 	<p>The confined vertical and horizontal members are relatively smaller.</p> 

C10 Hazard Resistant Features Of Walls and Openings

NDMA

Unnati

PIC

8

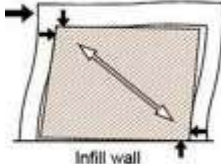
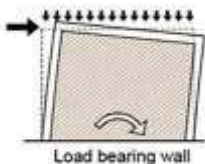
	RC Frame and Infill	Confined Masonry
Behaviour during Lateral In-place effects	<p>RC Frame is designed to take the vertical as well as lateral loads while the brick infill walls act as struts.</p> 	<p>The brick wall and the confining elements together act as one element to take the vertical and horizontal loads.</p> 

C10 Hazard Resistant Features Of Walls and Openings

NDMA

Unnati

PIC

9

Typical Damage to Walls

1. Corners separation



Separation of adjoining walls

2. Diagonal Cracks around openings



C10 Hazard Resistant Features Of Walls and Openings
NDMA Unnati PIC

12

3. Cracking of Masonry piers

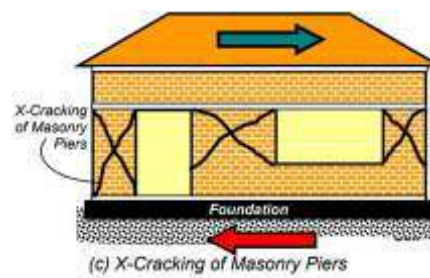
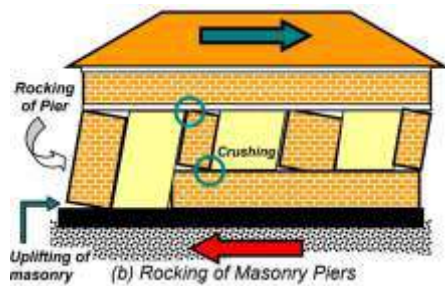
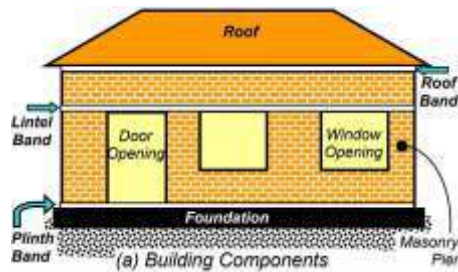

Earthquake response of a hipped roof masonry building - no vertical reinforcement is provided in walls.

C10 Hazard Resistant Features Of Walls and Openings
NDMA Unnati PIC

13

4. Delamination of Internal and External Surfaces



Bulging and Splitting of Stone Wall: If there are not enough through stones to bind two faces of the walls together, the wall behaves as two separate walls.

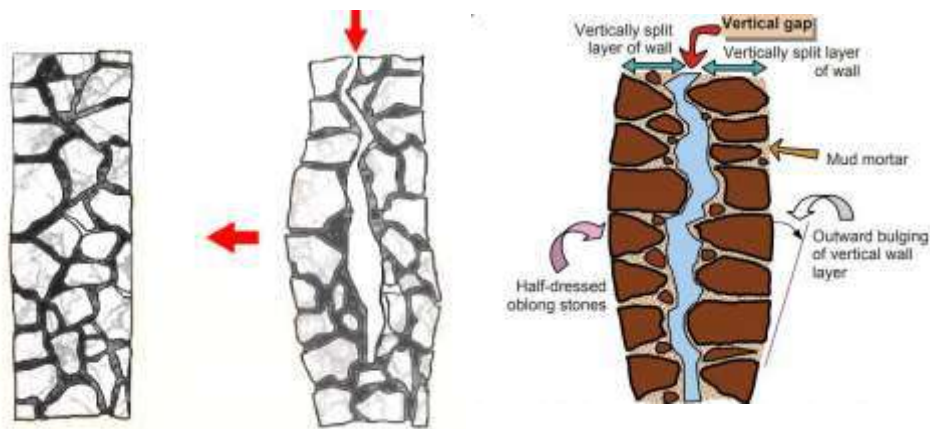

Schematic diagram of the wall section of a traditional stone house- thick walls without stones that go across split into 2 vertical layers.

5. Out of Plane Failure: As long walls behave differently at different points along their length during vibrations, long walls are vulnerable.



6. Column damage during earthquakes (Short column effect)

If the infill wall is not of full height of a storey, it adds to the stiffness of the column over a part of the height of the column. Since stiffness means resistance to deformation, portion with walls resists the earthquake forces, while the remaining part of the column is exposed to larger amount of lateral forces. If such part is not designed to resist these loads, it can suffer significant damage during an earthquake.



Masonry piers cracking

Principles of Hazard Resistant Walls

1. A thick wall is more stable than a thin wall.
A wall of short height is more stable than a tall wall.

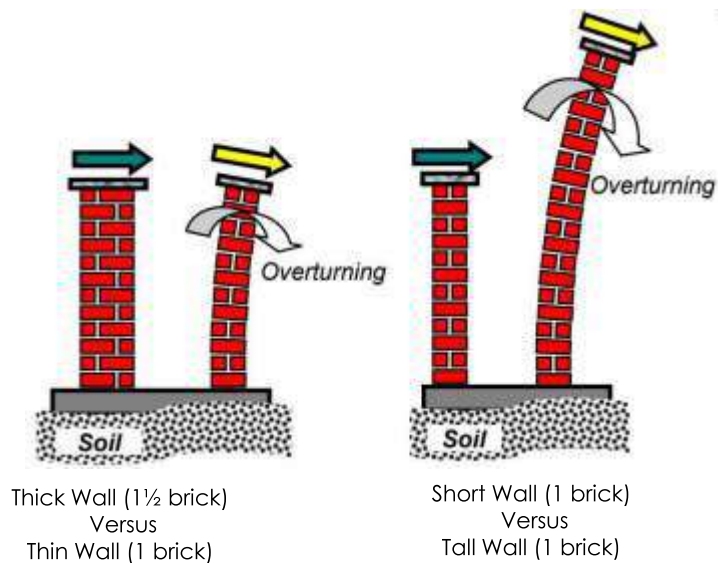

2. A short wall is more stable than a long wall

Walls longer than 7m length needs to be supported by cross walls or pillasters.

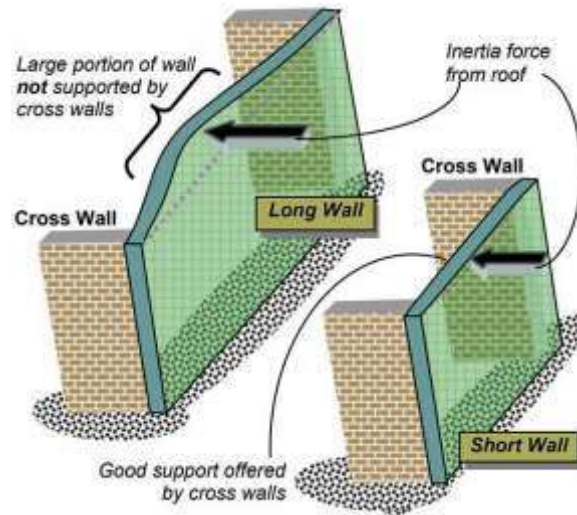

3. When an earthquake strikes, walls perpendicular to the direction of the earthquake are subjected to stronger force. Here, given the direction of the earthquake, walls in the direction of B tend to fail.

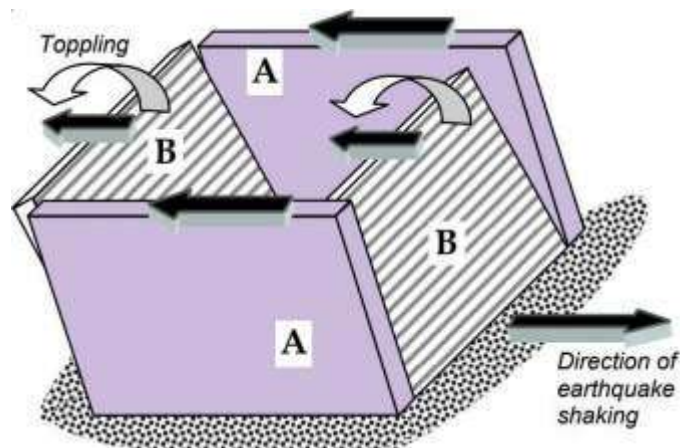

By connecting adjacent walls properly, **box action** ensures that the entire structure moves together and the loads are transferred from the weaker walls to the stronger walls with respect to the direction of the shaking.

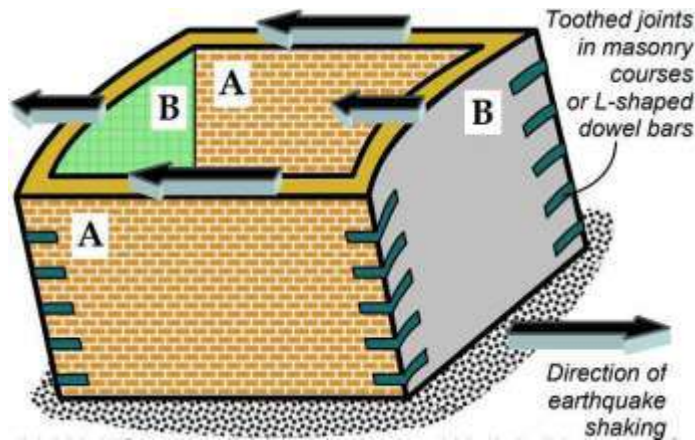

C10 Hazard Resistant Features Of Walls and Openings
NDMA Unnati PIC

4. Houses with horizontal bands are better

Types of bands in a building

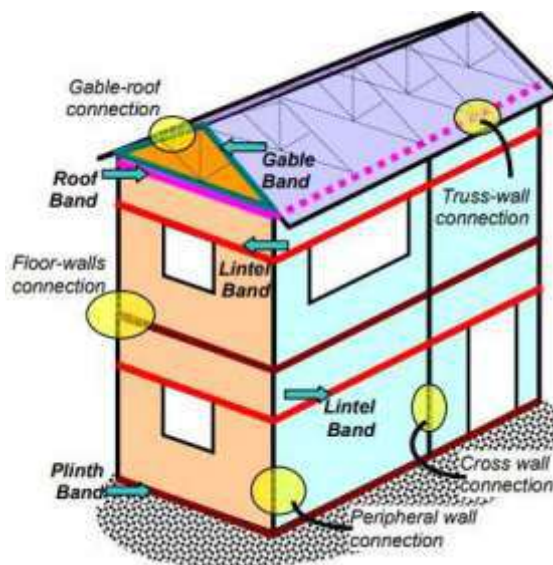

(a) Building with no horizontal lintel band: collapse of roof and walls



(b) A building with horizontal lintel band in Killari village: no damage

C10 Hazard Resistant Features Of Walls and Openings
NDMA Unnati PIC

Details of Hazard Resistant Walls

1. Masonry Bonds: English Bond

Avoid vertical joints by ensuring that proper bond is maintained.

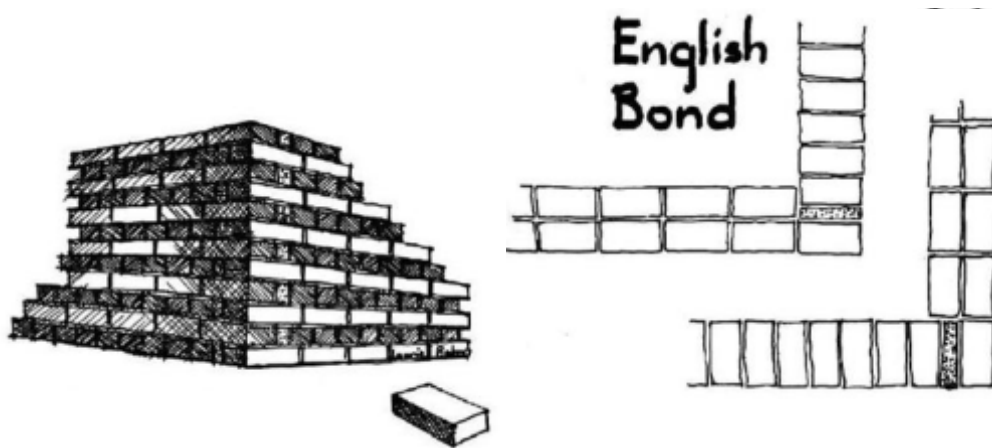

1. Masonry Bonds: Flemish Bond

One must avoid vertical joints by ensuring that proper bond is maintained.

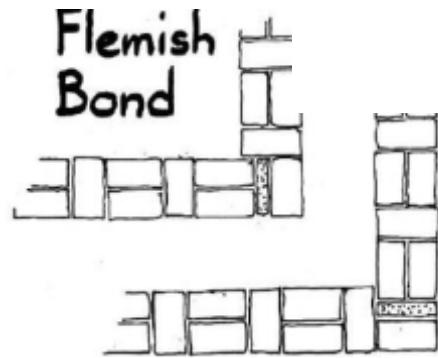
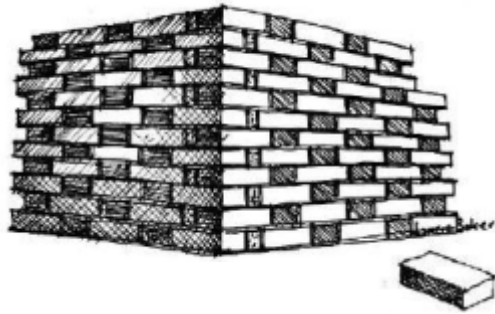

1. Masonry Bonds: Rat Trap Bond

One must avoid vertical joints by ensuring that proper bond is maintained.

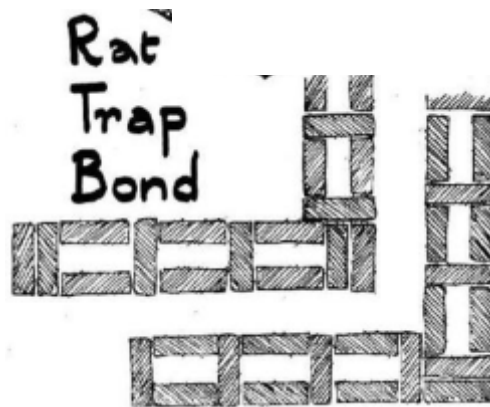
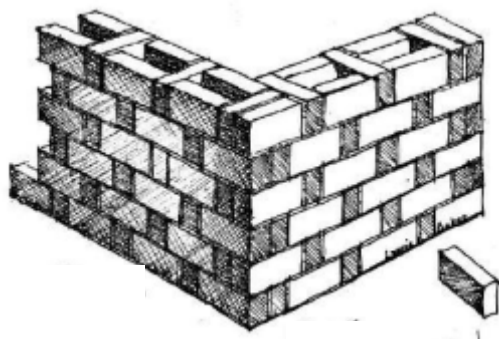

Importance of Staggering Joints

Joints in a wall should be staggered such that the wall behaves as one monolithic unit. Otherwise, during the effects of a hazard, the wall may behave as separate parts and split where the joints are not staggered.

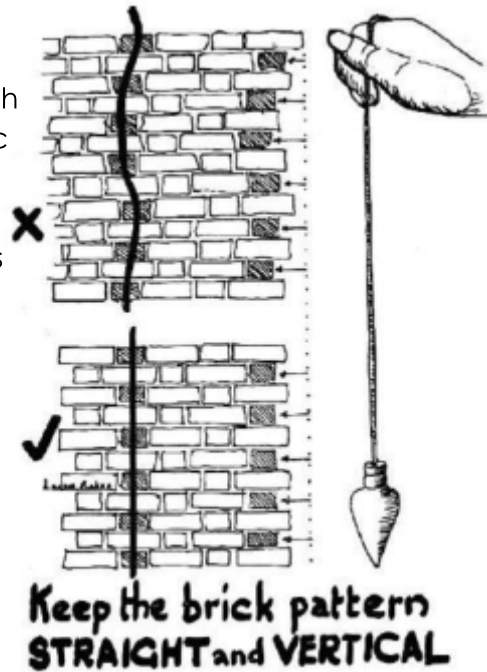

2. Random Rubble Masonry

At regular intervals, the random rubble masonry should be brought to leveled course.



Random Rubble
Masonry must be
done in courses

Max. Course
height = 600
mm

All voids must be filled completely with smaller stones and minimum possible mortar.

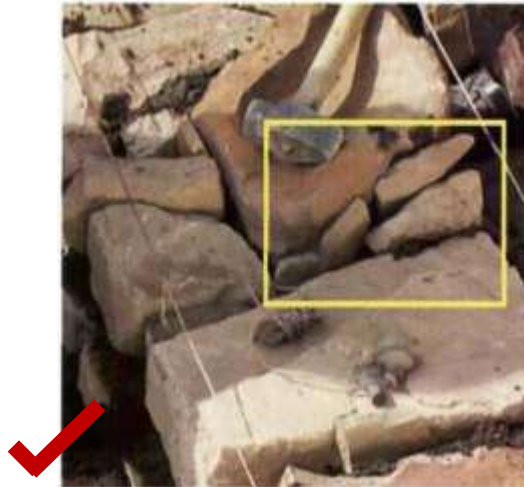

C10 Hazard Resistant Features Of Walls and Openings
NDMA Unnati PIC

30

Placing Through Stones in a Stone Wall: Through stones are used to hold the layers of the wall together to prevent splitting.

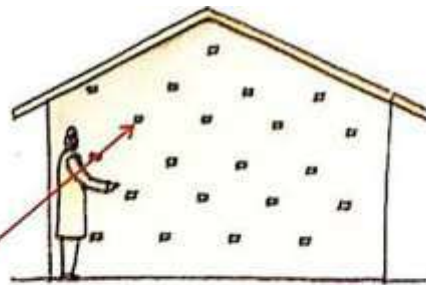

Provide at least one "through stone" at every 1200 mm horizontal distance in the masonry and at every 600 mm height in staggered manner.

C10 Hazard Resistant Features Of Walls and Openings
NDMA Unnati PIC

31

Placing Through Stones in a Stone Wall

1. Minimum Distance until a through stone is required:
At a distance of every 1200 mm for a 400 mm thick wall and at height of 600 mm.
2. They must be staggered as much as possible across the wall.
3. If appropriate through stone is not available, concrete block of required length, may be cast in-situ to create such stone.

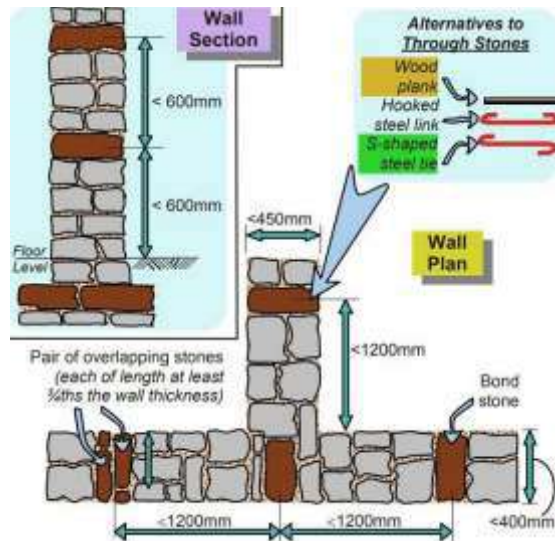

3. Horizontal bands in a structure are important to ensure that the entire building behaves as one structure.

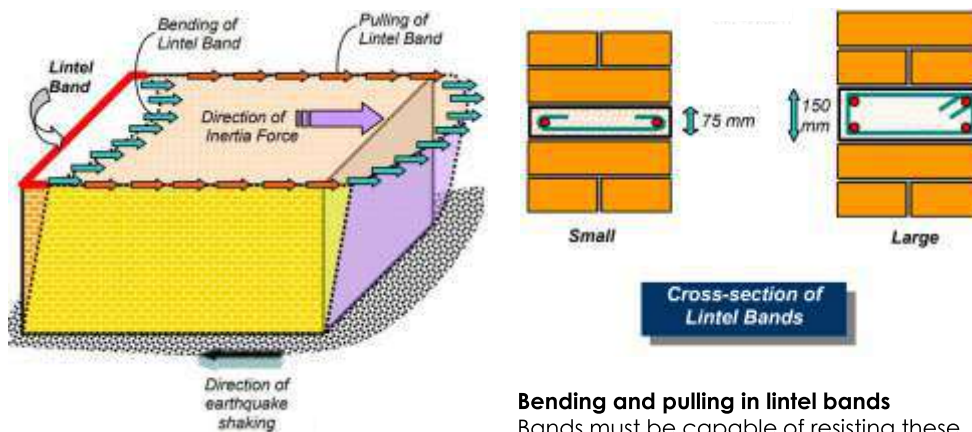

Difference between a Band and a Beam:

A horizontal band ties together all walls of a house, and therefore, helps transfer the **horizontal** loads between weak and strong walls depending on the direction of the forces.

A beam is meant to take the **vertical** load of the roof or other storeys, which it transfers to the walls or columns beneath it.

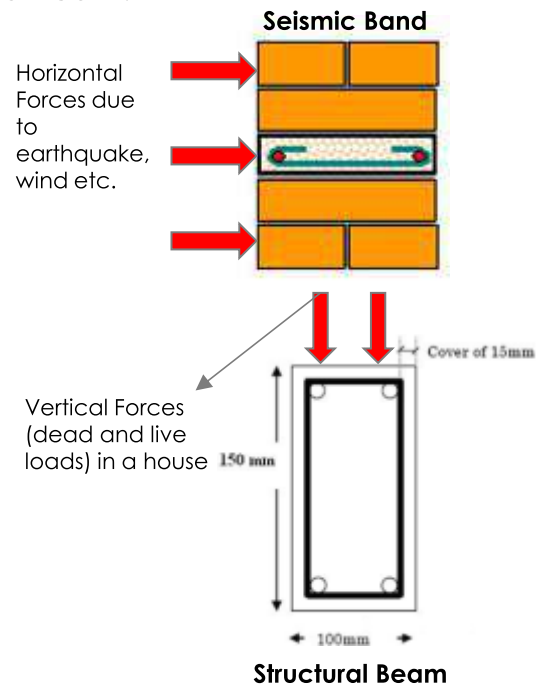

What is the requirement of Bands in different Seismic Zones?

1. Bands are Important to Strengthen Masonry Walls
2. All other bands are required in Seismic Zones IV and V.
3. Sill Band can be avoided in Seismic Zones II and III.

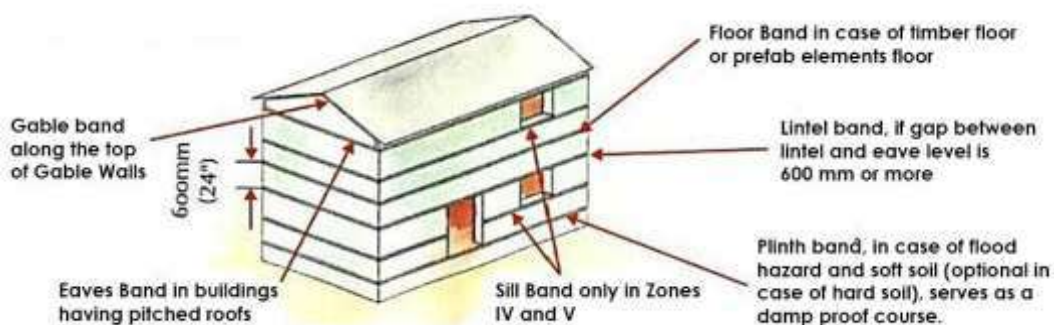

4. Details of Sill Band, Lintel Band and Eave Band

These Bands are to be made in the same way as the Plinth Band (C8). Things to be kept in mind are:

1. In an RC band, the longitudinal bars must be raised from the brick and 25mm inside from the face of the wall.
2. The junctions and overlaps will have 450 mm of overlap of the longitudinal bar, which will then be tied together.
3. The ends of the cross ties should be bent inwards across the band.
4. Bands can also be made with other materials, like bamboo ladder and timber ladder.
5. The junctions must be secured so that they transfer the loads evenly.

4.1. Connection of Eaves and Gable Band

The junction between the Eaves and Gable Bands must be secured to ensure box action.

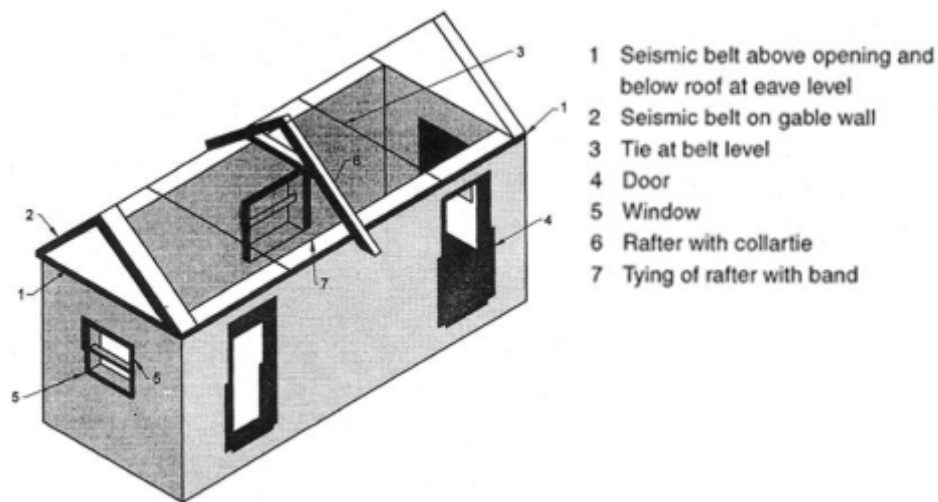

Provide two bars of same size in the Eaves Band and bent at the angle of the gable band. These will be overlapped with the bars in the Gable Band, which will make a secure junction to ensure the loads transfer evenly.

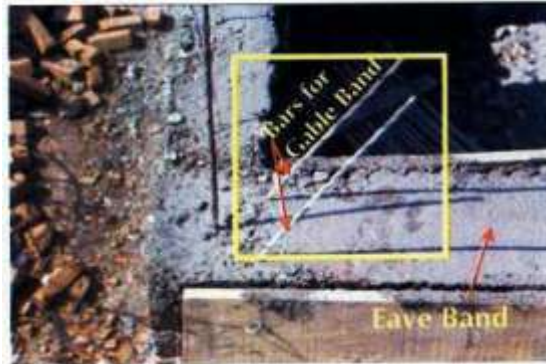

4.2. Gable Wall and Gable Beam

The height of the gable band should be not more than 1m above the Eave Band. The Eave Band and the Gable Band must both be provided.

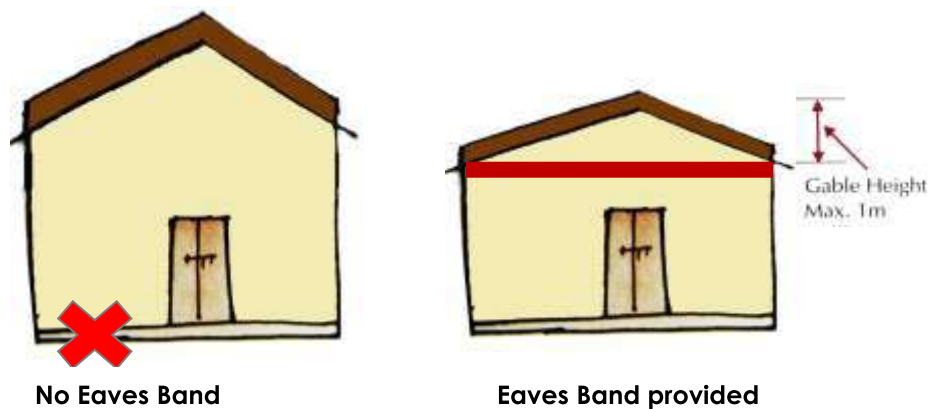

If Gable Wall is taller than 1 m, it is better to build it with light materials, like CGI sheet, wattle & daub or timber planks.

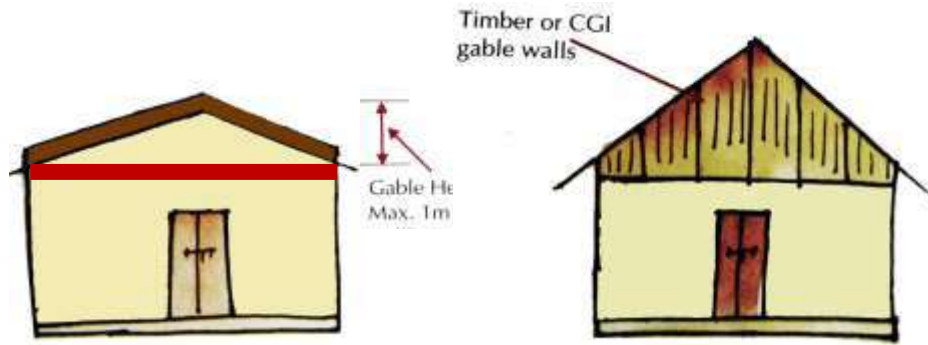

4.3. Anchoring of Roof to Walls

Anchor the ridge beam of a sloping roof and the intermediate beams of the roof to the Gable Band, so that the entire house behaves like a box.

Step1

Install a 12mm diameter 250 mm long bolt with a 100x100x5 mm MS plate welded at it's bottom in the band, where the ridge beam or rafter sits on the Gable Band.



Step 2

When the concrete of the band is poured and becomes hard, the ridge beam with a through hole can be attached over the bolt then anchored down using a washer and a nut.



5. Vertical Reinforcement

Vertical reinforcement is important to aid the transfer of stresses directly to the ground, especially at critical points, like corners and around openings.

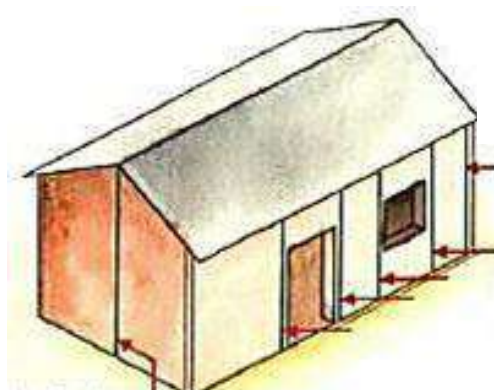

(a) At each room corner on all floors

(b) On either side of door openings, and preferably at window openings.

(c) In Cyclone Zone V under the ridge in gable wall

5.1. Vertical Reinforcement in Brick walls

The brick bonds are arranged in such a way that a cavity is created at the centre of the L or T junction around the reinforcement bar. The cavity is later filled with micro concrete in 450 mm lifts. The details of brick bonding with cavity for vertical reinforcement are given in C9. The reinforcement bar must be anchored at the foundation.

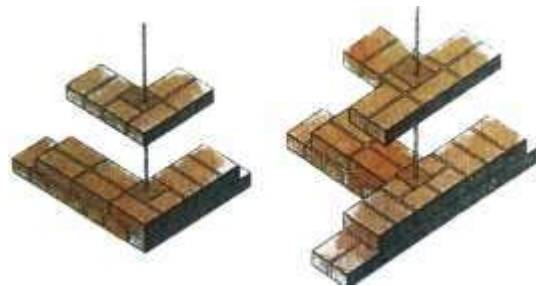

C10 Hazard Resistant Features Of Walls and Openings

NDMA

Unnati

PIC

44

5.2. Vertical Reinforcement in Concrete blocks

While using concrete blocks, use solid blocks which have a key hole or hollow blocks with a slot keep the reinforcement bar in the centre of the cavity. This cavity can then be filled with micro concrete.

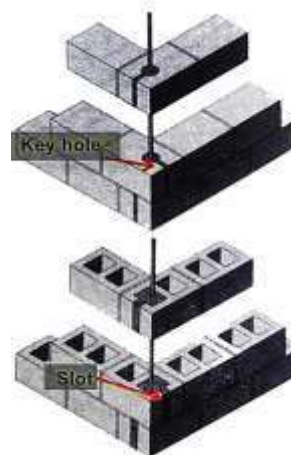

C10 Hazard Resistant Features Of Walls and Openings

NDMA

Unnati

PIC

45

6. How to strengthen slender and long Walls

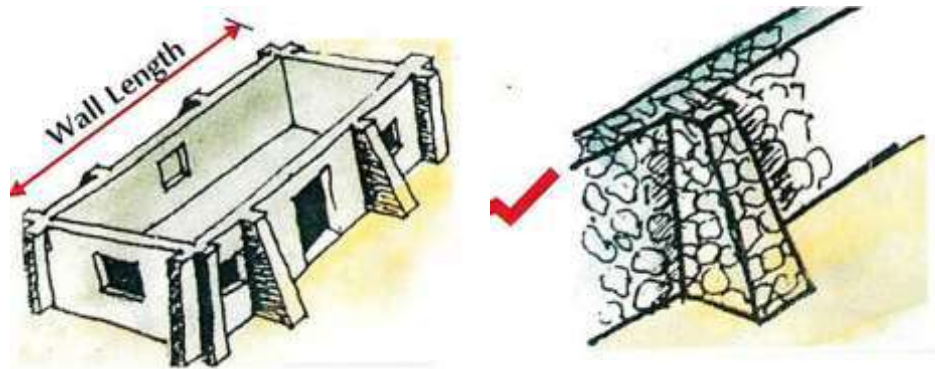

In long walls (more than 7m), buttresses must be provided.

C10 Hazard Resistant Features Of Walls and Openings
NDMA Unnati PIC

46

7. Load Bearing Non-Masonry Walls

Earthen walls are just as brittle as other masonry walls, and need to be protected from moisture in the air.



C10 Hazard Resistant Features Of Walls and Openings
NDMA Unnati PIC

47

7. Load Bearing Non-Masonry Walls

1. They need vertical reinforcement as well as bands to be strong and hazard resistant.
2. Their behaviour is similar to masonry walls, except when there is a lot of moisture in the atmosphere. Earthen walls, if not stabilised, lose strength in such a situation and may fail.



C10 Hazard Resistant Features Of Walls and Openings
NDMA Unnati PIC

48

8. Openings in Masonry Walls

The vertical reinforcement bars allow the entire house to act as one and bend accordingly, rather than shake as separate elements and cause more damage.

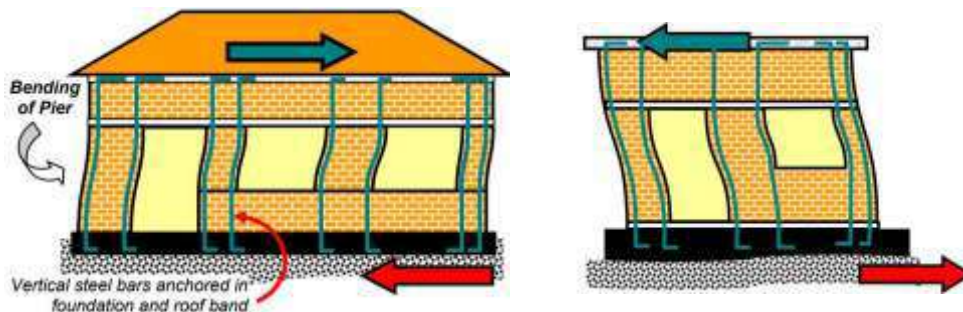

Vertical reinforcement bars cause bending of masonry piers instead of rocking.

Vertical reinforcement bars in masonry walls; wall behaviour is modified.

C10 Hazard Resistant Features Of Walls and Openings
NDMA Unnati PIC

49

i) Asymmetric openings cause uneven stresses on wall and can cause more damage.

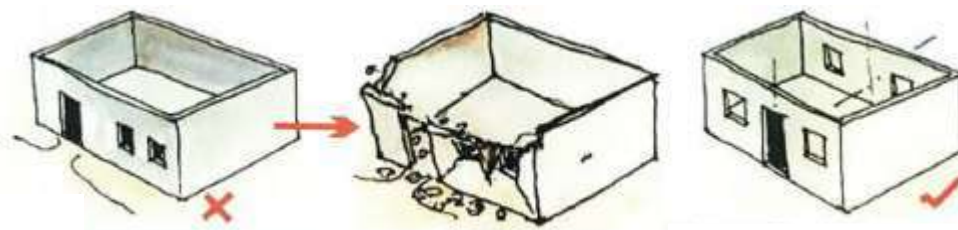

House with asymmetrically arranged wall openings can suffer more damage. For symmetry place identical openings in opposite walls.

When possible, place door in the center of the wall with openings placed symmetrically on both sides.

ii) Too many Openings on the same Wall cause Wall to collapse.

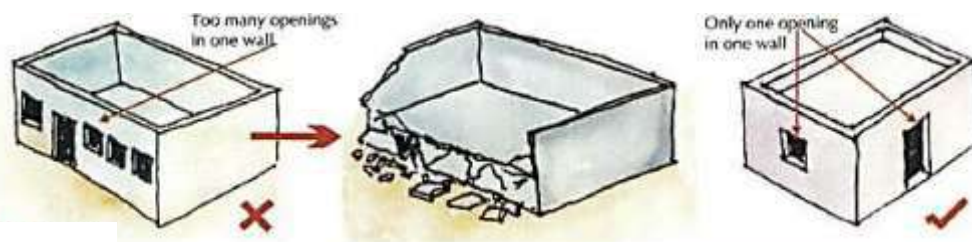

Walls with too many door and window openings close to each other could collapse easily. Openings should be restricted to small sizes and few in numbers.

In smaller rooms, provide no more than one opening in each wall.

iii) The Distance between inner edge of the corner and the edge of the opening must be significant.



If the gap "E" between inside corner and a door or a window opening in a wall is too small, the wall can get damaged easily.

The gap "E" should be larger for more strength.

iv) Distance between inner edge of wall and the edge of the opening should be at least $\frac{1}{6}$ th of height of wall.

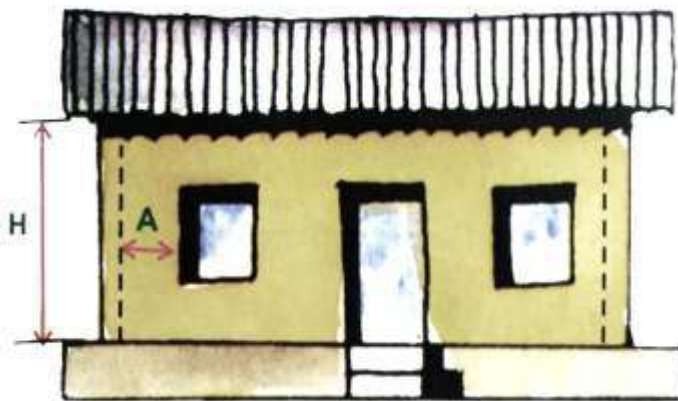

$$A \geq H/6$$

v) Avoid too many Openings on the same wall

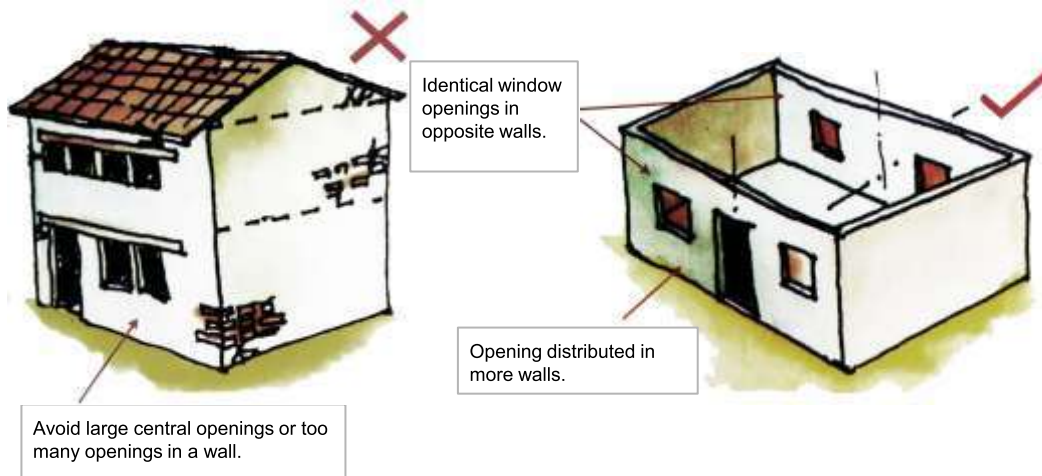

vi) In a cyclone prone area, ensure that all doors and windows can be sealed properly.

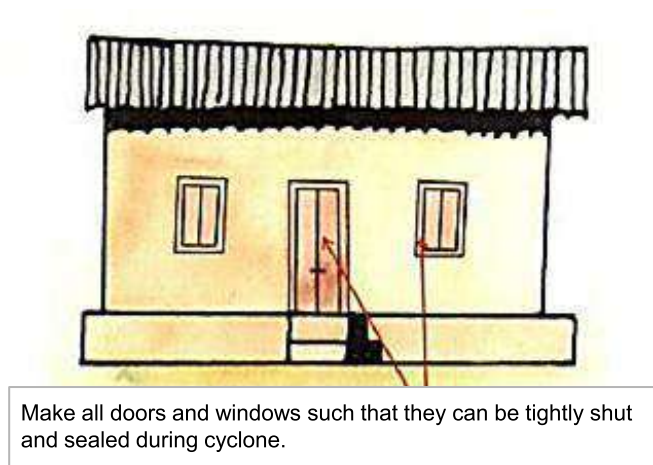

vii) The same lintel level should be maintained for all openings. Many different levels and sizes of windows cause stresses to affect the wall in an uneven manner and lead to more damage.

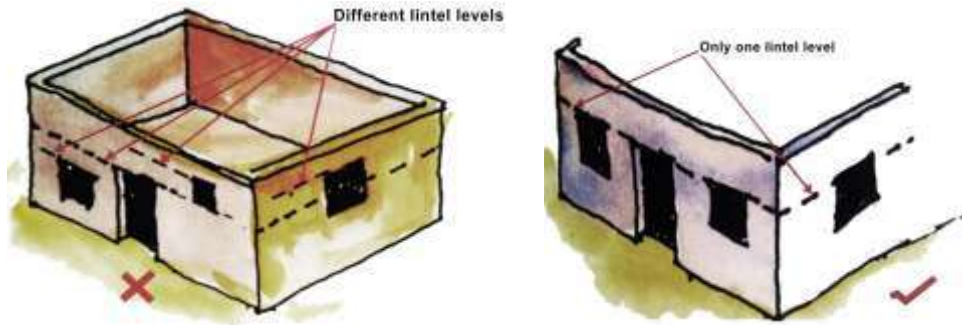

Maintain same lintel level for all openings. Try to keep all windows of same size. Many different sizes and levels make walls unsafe in earthquakes.

viii) $A+B+C$ should be relatively less in comparison to the wall length.

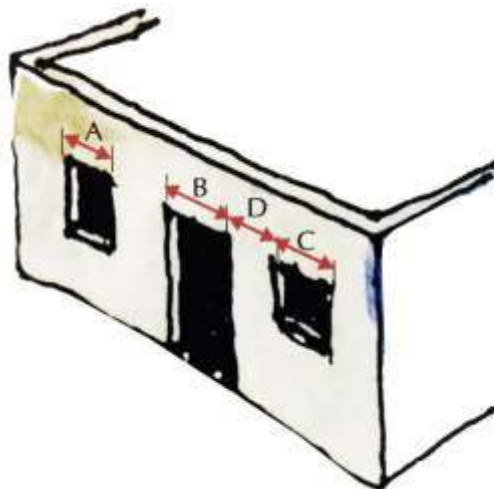

Summary

1. Typical damages to walls during various hazards: Failures of corners, diagonal cracking around windows, and splitting of thick walls
2. Basic principles of making walls and openings: We discussed box action, slender vs thick walls, long vs short walls and corner strengthening.
3. Details of making walls, including vertical reinforcement, different types of bonds, importance of horizontal bands, importance of staggering the joints, through stones, confined masonry and buttressing.
4. Windows and doors play a pivotal role in hazard resistance. The size of the opening, its location with respect to the wall and other openings, all affect the way the wall will behave during a hazard.
5. Openings should be symmetrically placed. They should not be too close to each other. There should be enough wall area between two openings.

P11

Constructing Hazard Resistant Walls

No. of Slides: 6
Time: 4 hours 30 min.



National Disaster Management Authority



Unnati
Organisation for Development Education



People in Centre

Expected Outcomes

Participants understand and learn to implement critical details and methods of wall construction.

P11 Constructing Hazard Resistant Walls
NDMA Unnati PIC

2

Participants will form groups of two; each group will have one labor to assist them. Each group will construct a different load bearing wall of 1.2 m height and 1.8 m length approximately. Each wall should be made in a C-shape or Z-shape.

P11 Constructing Hazard Resistant Walls
NDMA Unnati PIC

3

Types of Load Bearing Walls

1. Brick Masonry with English/Flemish bond
2. Brick Masonry with Rat Trap Bond
3. Coursed Random Rubble Stone Masonry
4. Confined Masonry with Bricks
5. Block Masonry (compressed stabilised earth block, concrete hollow block, concrete solid block)

Each group must construct the wall with the following features:

1. One Horizontal band
2. L or T junction with appropriate detail
3. Detail for jamb of an opening
4. Use of Through Stones in Masonry

Discussion

Discuss the different types of walls made along with the positive points and negative points of each wall. Ensure all topics till C9 are covered.

C12

Hazard Resistant Features : Roofs and Ceilings

No. of Slides: 45
Time: 3 hours



National Disaster Management Authority



Unnati
Organisation for Development Education



People in Centre

Expected Outcomes

1. Participants know about various roof types observed in the region – sloping, flat roofs and other types.
2. They can analyse the problems and weaknesses in roofs that result in damages to the buildings and learn how to mitigate them.

Roofs : Materials and Construction Systems

Sloped:

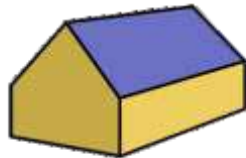

Gable Roof

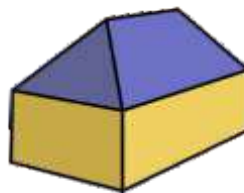

Hipped Roof

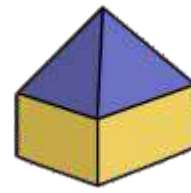

Pyramid Hip Roof

Flat:

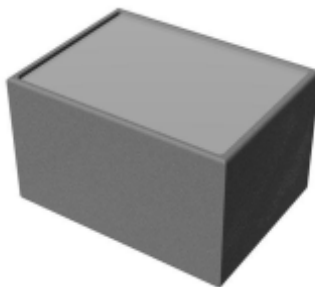

Sloping Roof Systems

Two primary systems based on roof elements:

1. Ridge - Rafter - Purlin System

The load of the roof is primarily on the ridge beam and gable walls.

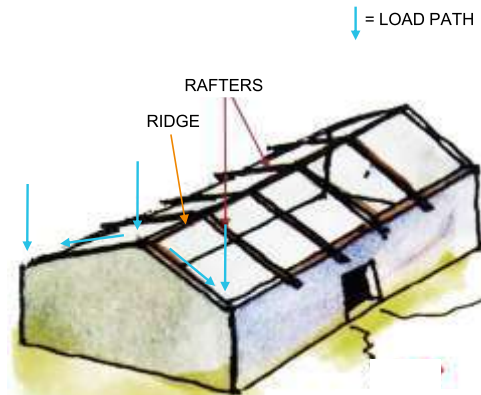

2. Truss System

The load of the roof is primarily on the truss, which rests on the two longer walls.

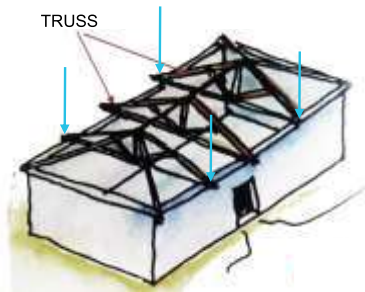

Flat Roof Systems

1. Plank-joist: Pre-cut or pre-cast planks (usually made of stone, bricks or precast concrete) placed on top of joists (pre-cast or in-situ) that span between the walls

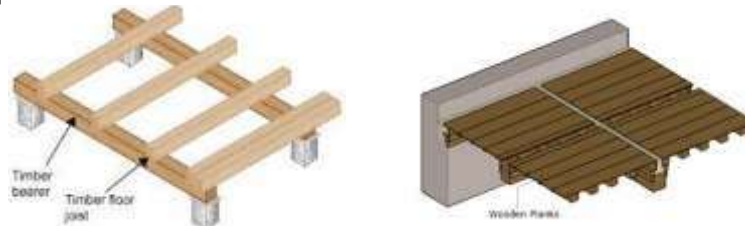

2. RC: Reinforced Concrete slabs as roof slab

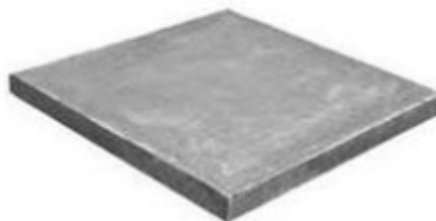

3. Filler Slabs: The lower part of a slab does not need to be concrete and so lighter materials (like mangalore tiles or clay pots) are used to replace concrete in that portion. This makes the structure lighter and cost effective.

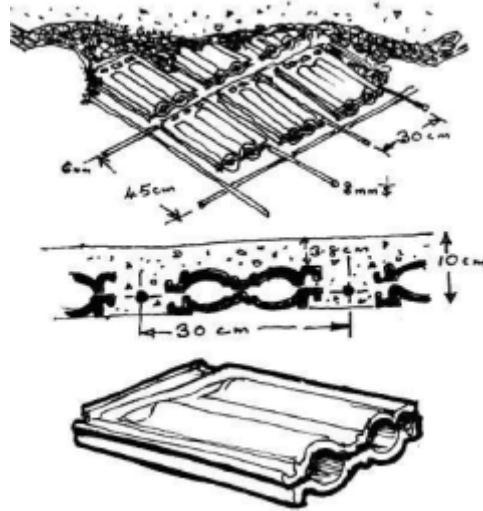

One-Way Slab and Two-Way Slab

Depending on how the load of the roof transfers to the ground, the ceiling could either be spanning in either of the two ways.

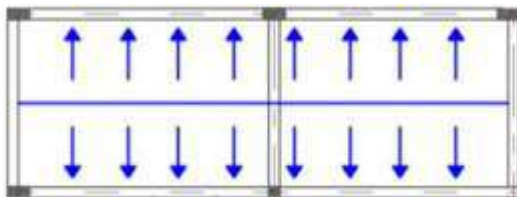

One way slab supported by beams only on 2 sides

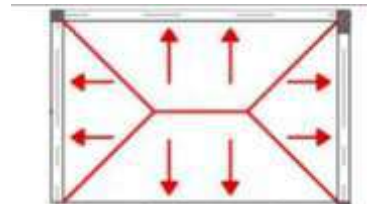

Two way slab supported by beams on all 4 sides

One Way Slab	Two Way Slab
One way slab is supported by beams in only 2 sides.	Two way slab is supported by beams in all four sides.
The ratio of longer span panel (L) to shorter span panel (B) is equal or greater than 2. Thus, $L/B \geq 2$	The ratio of longer span panel (L) to shorter span panel (B) is less than 2. Thus, $L/B < 2$.
Main reinforcement is provided in only one direction for one way slabs.	Main reinforcement is provided in both the direction for two way slabs.

During an earthquake, forces are induced in all directions . Hence, load of the roof needs to be transferred in all directions as well. So, all four walls of the house need to be capable of resisting the weight of the roof, else the house may collapse. If the earthquake comes in the weaker direction, the impact will be greater.



Never support RC slab on two walls only. In case of one wall collapsing, the whole roof can collapse.

Support RC slab on all four walls

Pros and Cons of Different Roof Systems

Flat Roof is preferable in flood prone areas to have a floor to climb to.

Sloped Roof is preferred in areas with high rainfall to ensure the water runs off and protects the walls with its large overhangs.



How to decide what kind of roof to make?

The choice of roof depends on several factors and the decision should be made before the foundation is built.

Depending on the types of the roof, one would know whether it spans across two walls or all four walls, and therefore which are the primary elements that will carry the load to the ground during a hazard. It helps deciding foundation depth and details.

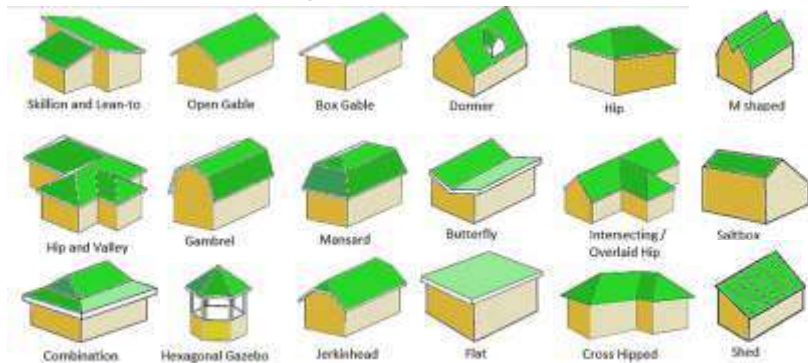

C12 Hazard Resistant Features of Roofs and Ceilings

10

NDMA

Unnati

PIC

Discuss any other roofing system prevalent in the region.

Typical Damages to Roofs

Damage due to uplifting of the roof



Damage primarily caused by strong winds

Lack of Vertical Load Transfer



Damage due to strong winds

C12 Hazard Resistant Features of Roofs and Ceilings
NDMA Unnati PIC

14

Damage to Gable Wall



C12 Hazard Resistant Features of Roofs and Ceilings
NDMA Unnati PIC

15

Damage to Light Roof vs Heavy Roof

	Earthquake	Cyclone or Windstorm
Light Roof	Less damage to the building, because of less self weight that needs to be carried to the ground.	A light roof may easily get swept up and uplifted because the wind does not need to have too much force to do so. It may easily fly off if not anchored properly.
Heavy Roof	Can cause more damage due to its self weight by crashing into the gable wall (sloping roof) or the supporting walls (flat roof) and cause damage to walls and columns, as they need to take its weight down to the ground.	A heavy roof is much harder to uplift and it clamps down on the walls and columns, It will firmly hold the roof down during a storm.

Damage to Light Roof vs Heavy Roof

Damage to light roof due to cyclone

Damage to heavy roof due to earthquake



Principles of Hazard Resistant Construction

1. Diaphragm Action

The roof acts as a diaphragm to transfer lateral loads in a flat roof.

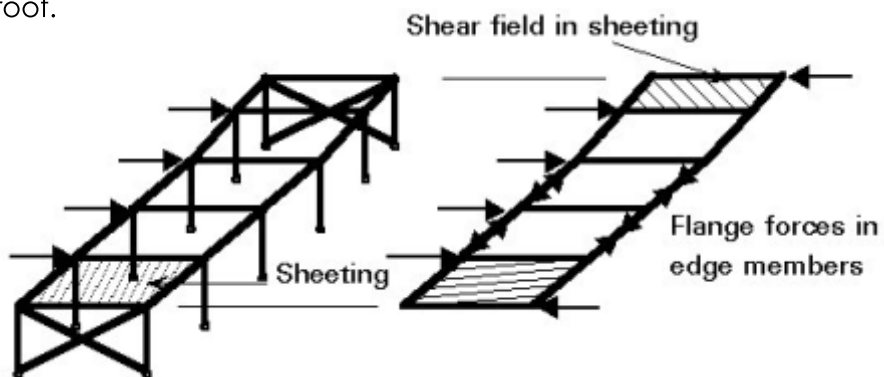

The diaphragm-like roof sheeting, a single continuous membrane, where panels acts as **'web'** resisting shear, while diaphragm edge members does the function of a **'rim'**, resisting bending stress.

The roof acts as a diaphragm to transfer lateral loads in a sloped roof.

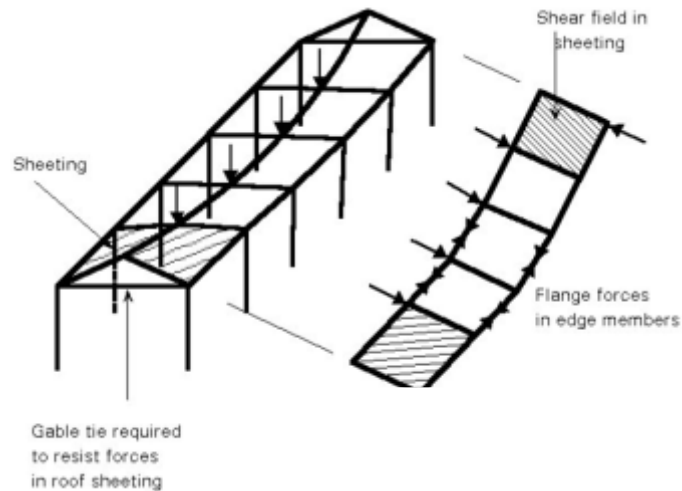

2. Box Action



The roof ties the entire box together such that the entire house behaves like one box, and transfers its loads to the ground easily.

A closed cardboard box is always stronger than an open box.

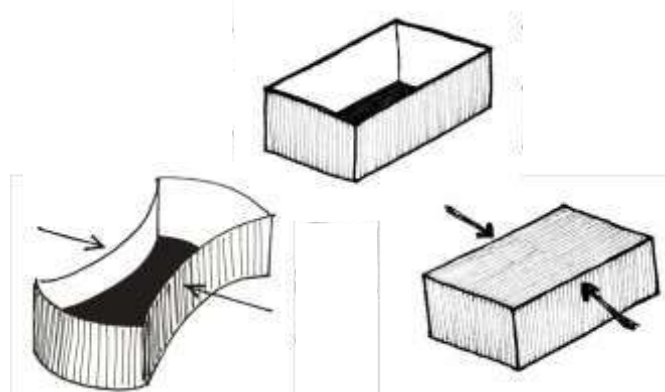



3. Anchoring Floors and Ceilings to Walls

The joists of the floor above should be placed on top of a horizontal band, which is placed on top of a wall and **anchored** properly, instead of being placed there directly.

The roof rafters or trusses must be placed on a wall plate and **anchored** well to ensure the load is distributed on the entire wall.

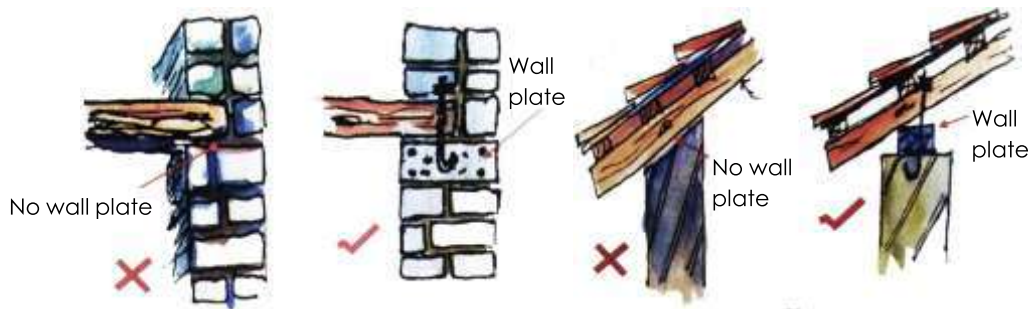

C12 Hazard Resistant Features of Roofs and Ceilings
NDMA Unnati PIC

4. RC Flat Roof

The reinforcement cage must be made according to the design of the slab and how much it is supposed to span. Mason needs to ensure that all reinforcement is covered with concrete (In humid areas, at least 30mm) and the reinforcement bars of the roof are tied properly to the vertical reinforcement bars from the foundation with proper overlap.



C12 Hazard Resistant Features of Roofs and Ceilings
NDMA Unnati PIC



5. In-plane bracing of Roof

If the roof is not braced, in-plane deformation with rectangle changing into a parallelogram results in side-ways push to gable walls. To avoid this, **diagonal bracing** is done on the underside of the roof framing.

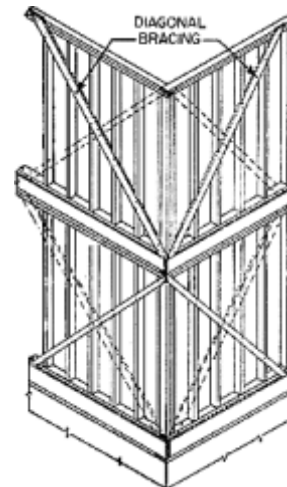
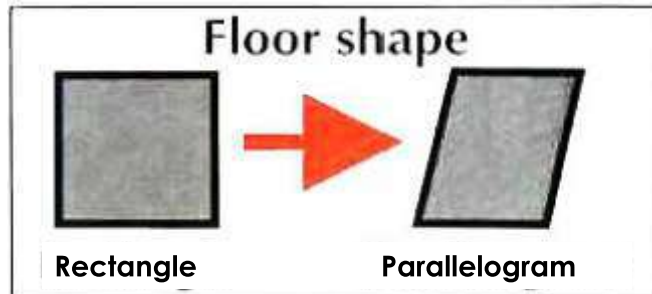

Bracings can be added by installing wooden struts on which the diagonal bracings are fixed. To do this, rafter/purlins and the struts should be pre-drilled before the roof is installed.



1. Pre-drill planks and rafter/purlins.

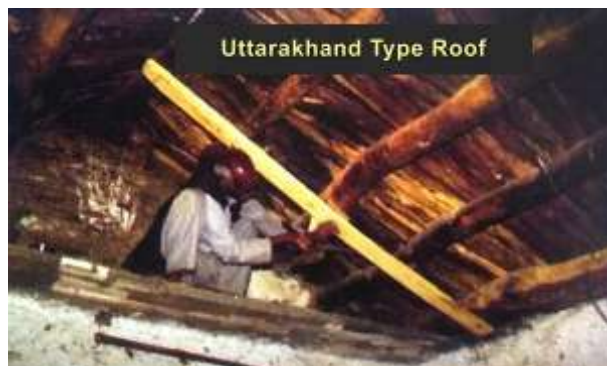

2. Using two nails at each end install a 100mm x 25mm strut (plank) on the underside of purlins adjacent to their ends.

Install diagonal bracings starting from one end of a strut at the far end maintaining the angle close to 45°. More than one set of bracings should be installed, if the angle is too steep.

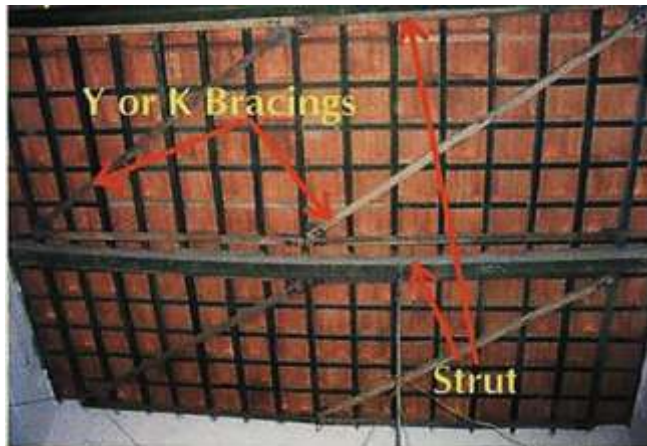

In-plane Bracing in Intermediate Floor

1. Pre-drill planks and floor joists and use two nails at each end.



2. Install 100mm x 25mm struts (plank) on the underside of the floor joists adjacent to the walls that support the joists.



In-plane Bracing in Intermediate Floor

3. & 4. Install diagonal bracings of same plank.



C12 Hazard Resistant Features of Roofs and Ceilings
NDMA Unnati PIC

28

6. Alternative Option for Bracing

As an alternative, 5 strands of 13 gauge GI wire (2.4 mm dia) can be used. Stretch them taut and install them on the struts in X configuration.

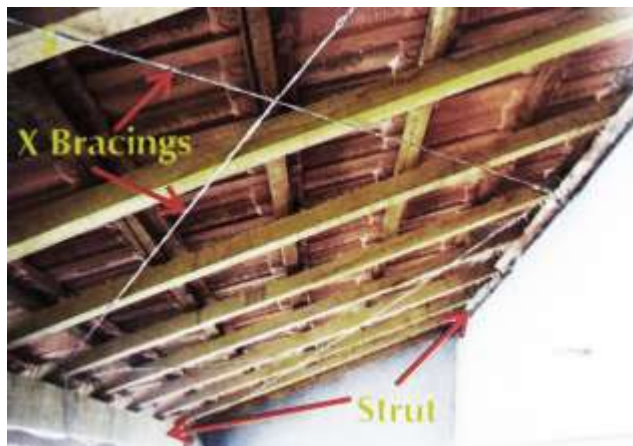

C12 Hazard Resistant Features of Roofs and Ceilings
NDMA Unnati PIC

29

257



Tie one wire at a time around the joint of strut with rafter or purlin, stretched with a carpenter's hammer.



Pre-tension wires by twisting all wires along one diagonal together with a piece of rebar.

7. Anchoring Timber Floors to Walls

1. Install 100mm long MS angles 35 x 35 x 3 mm in the floor level band at each joist locations.



2. Angles to have two holes 14mm in diameter



C12 Hazard Resistant Features of Roofs and Ceilings
NDMA Unnati PIC

32

3. Connect floor joists with 2-12mm diameter bolts



4. Alternatively, install 6mm bar or 10 gauge GI wires (3.25 mm dia) in concrete as anchor



C12 Hazard Resistant Features of Roofs and Ceilings
NDMA Unnati PIC

33

8. Installing Collar Beams for Rafters in Pitched Roofs

At 2/3rd height of the roof/attic install 35 x 100mm wooden plank collar beam across the opposite rafter using nails.



C12 Hazard Resistant Features of Roofs and Ceilings
NDMA Unnati PIC

34

9. Fixing of Ridge Beam on Gable Wall

1. Install 12mm diameter bolt 250mm long with a 100 x 100 x 5mm MS plate welded at its bottom in the band at the right location.



C12 Hazard Resistant Features of Roofs and Ceilings
NDMA Unnati PIC

35

2. Once concrete becomes hard, place timber beam with a through hole over the bolt and place a washer and a nut to anchor it down.



10. Anchoring Pitched Roof Support Structure to Wall Rafter and Purlin System

1. MS angle 35 x 35 x 3mm, 75mm long installed in eave or gable band for anchoring rafters and purlins.



Alternatively,

2. 6mm MS bar installed in Eaves Band to anchor purlin or rafter by simply bending over them

3. Pieces of 10 gauge GI wires (3.25 mm dia) attached to reinforcing bars in eave band leaving 300 mm long ends projecting out



C12 Hazard Resistant Features of Roofs and Ceilings

38

NDMA

Unnati

PIC

4 & 5. Tie down rafters with two strands of 10 gauge GI wires (3.25 mm)

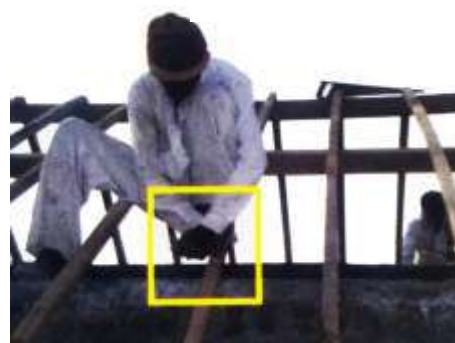

C12 Hazard Resistant Features of Roofs and Ceilings

39

NDMA

Unnati

PIC

11. Securing Roofing to Roof Frame and Wall

Tying of Roofing Tiles or sheets



In areas with high wind speed use galvanized metal straps along with 2 nails. Pre-drill the pilot holes.

Alternately, cheaper and easier option is tying together of elements with 2 10-gage GI wires (3.25 mm dia).



Connection of purlins & rafters, and beam & rafters.

12. Tying of Roofing Sheets



'J' hook

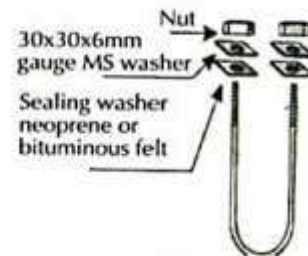

'U' hook
Wind Speed Zone V only

Secure roof sheeting to purlins using 'J' hooks or 'U' hooks.

Hooks must be installed with nut, 6 gauge MS washer followed by washer of Bituminous Felt or Neoprene.



The holes in sheeting must be made in ridges to minimize water leakage.

13. Anchoring Roofing Tiles

In cyclone prone regions, tie each tile or every other tile to the purlins with a GI cyclone hook.



Anchor each tile or every other tile to purlin with GI hooks.

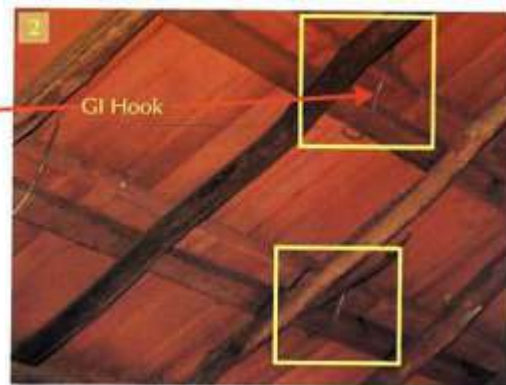

The lowest row of tiles get the maximum pressure of uplifting from below. At eave level they should be tied down with 2 10-gauge GI wires (3.25 mm dia) or a 6mm MS rod from one end to the other.

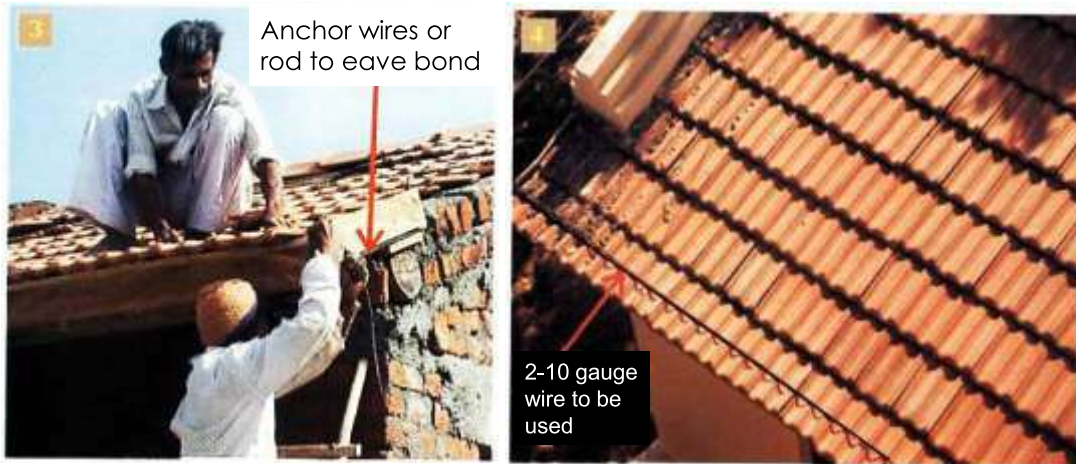

Summary

1. We discussed, that roofs can be sloped or flat. Sloped roofs can be made in a rafter-purlin system or by a truss system. Flat roofs could be made by plank and joist, RC slabs or filler slabs.
2. A flat roof could be spanning one-way or two-way, based on how the load transfers to the ground.
3. Typical damages to roofs, due to various hazards are discussed with various pros and cons of different roof systems in different hazards.
4. Principles of hazard resistant roof construction, such as diaphragm action, in-plane bracings, and details showing practical application of these principals.

P13

Constructing Hazard-Resistant Roofs and Ceilings

No. of Slides: 6
Time: 4 hours 30 min.



National Disaster Management Authority



Unnati
Organisation for Development Education



People in Centre

Expected Outcome

1. Through practical implementation, participants understand critical details and methods of roof construction.

Participants will form groups of two. Each group will build a plank and joist roof and RC roof details, followed by discussion on these samples.

Further, there will be discussion on filler slab, gable and hipped roofs through full-scale demonstrations or scaled models.

Flat Roof

1. The participants will construct a stone plank and joist roof, on two parallel walls, followed by discussion on these samples constructed.
2. Assembling of reinforcement for RC slab
3. Demonstration of RC slab reinforcement details for one way and two way slabs, edge beam reinforcement, column to roof steel detail at junction

Sloping Roof

Demonstration of design of truss system and design of ridge beam, rafters, purlins system, different elements and joinery of roof to wall, wall plate, eaves detail, in-plane bracings, etc.

Points for Discussion

1. Roof and Wall junction in flat and sloped roofs
2. Tying of different roof elements through joinery
3. Design of truss
4. Joinery of vertical reinforcement, roof band and the slab in different conditions, such as:
 - (i) Vertical corner reinforcement bar,
 - (ii) Vertical RC elements of confined masonry, and
 - (iii) No vertical reinforcement.

P14

Field Visit:

Rural House Construction and Materials Available

No. of Slides: 15

Time: 8 hours



National Disaster Management Authority



Unnati

Organisation for Development Education



People in Centre

Expected Outcomes

1. Participants can identify common construction problems pertaining to hazard resistance in their context and understand the application of hazard resistant features.
2. They develop knowledge about good quality materials available in the market.

1. Construction of a House

Field visit to a nearby village to observe houses (already constructed or under construction) and identify the hazard resistant features included or omitted in such constructions in practice in the region. The key focus will be on how the principles learnt need to be interpreted in practice and what details will be necessary to replicate or evolve.

Trainer needs to identify examples in advance in a nearby village or settlement, where the participants can be taken to discuss the construction practices and these features of hazard resistant construction.

What to Observe?

The following are suggested questions to be answered while visiting houses:

1. What is the hazard risk profile for this region?
2. What is the primary hazard these houses need to be resistant for?

Site, Soil and Foundations

3. Is there anything about the site or its surroundings that makes the house vulnerable to damage during a hazard? (Steep unstable slope, being in a floodplain of a river, too close to the sea, the soil is too sandy or too clayey, possibility of earthquake, cyclone, landslide, etc.)

4. What about the site of the house is advantageous in terms of hazard resilience? (Are there trees or mounds that can act as wind breakers against a cyclone, is the soil hard and stable - unlikely to expand and well graded, there is a gradual slope and enough space for water to drain out, etc.)
5. Is the house well anchored to the ground? What is the type of foundation and how deep it might be?
6. Is the plinth protected well? Are the features (like extended plinth, or roof overhang) sufficiently provided or needs to be improved?

Walls and Openings

7. Is there vertical reinforcement in the walls? If yes, is it anchored to the foundations, to intermediate bands and to the roof?
8. What are the appropriate horizontal bands required for the region? Are they present in the house? Is there a Plinth Band, Sill Band, Lintel Band, Eave Band and Gable Band?
9. Is the masonry of the wall made well and of good quality? Are the materials that have been used are of good quality? In case of stone construction, are there enough through stones and are they staggered properly? Check bricks/ stones, sand, aggregates, timber, steel, etc.

10. **If in an earthquake prone area**, (i) Check if the windows are in accordance of safe building practices. (Are there too many windows compared to the available wall area? Are they all at the same level and tied by the Lintel Band? Is there sufficient distance from the edge of the corner of the house?) and (ii) Check if the roof is light or heavy, and whether it should be made differently, with lighter materials?
11. Are the openings protected from natural elements (rain and heat)?
12. Are members of the roof properly anchored to each other? Will it resist possible hazards in the region such as earthquake, cyclone etc.?
13. **If in a cyclone prone area** (i) Check if the windows can be tightly sealed and (ii) Is the roof light or heavy?

Roofs, floors and Ceilings

14. Is the roof properly anchored to the walls? Is there a wall plate/Eave Band to which the roof or floor has been anchored?
15. Should the roof overhang be more (for flood/ rain) or less (for cyclone)?

Other elements

16. If the staircase is built in masonry, is the structure separated from the main structure? If not, have the vulnerable parts of the structure been strengthened?
17. Are the cantilevers too large?

Points for Discussion

1. Which hazard resistant features do you think are absolutely necessary and that they should have been incorporated in the house?
2. Discuss with the owner, if present, whether he/she would be willing to invest in hazard resistant features?
3. How would you convince the owner/client to prioritise in favor of the hazard resistant features?

2. Material Suppliers

In the second half of the day, a visit to the nearby material suppliers will be planned. There you will discuss the available materials and its quality. Also, discuss the difference in rates of good and bad quality materials.

The trainer pre-identifies one or more suppliers in nearby area. He moderates the discussion and helps the groups to conclude their findings on the quality and recommendations for use.

What to Observe?

For each material, check the different qualities available and their rates. Check the following materials with the tests done in the practical session P4:

1. **Brick:** Drop test, sound test, scratch test and observations about color and edges
2. **Stone:** Different shapes, length, flaky or smooth
3. **Sand:** Well graded (particle size), checking salt content, checking whether clean
4. **Concrete blocks:** quality of edges, texture, drop test, strength
5. **Wood:** Section size, straightness, knots, soft and hard, identifying species, colour, texture, grains, smell, check for borer

6. **Bamboo:** Wall thickness, taper, diameter, knot distance, maturity, species of bamboo, check for borer
7. **Cement:** ISI mark on bag, check grade, check for moisture
8. **Steel:** ISI mark, TOR steel, corrosion, checking diameter, checking whether re-rolled. (½ hour)

Points for Discussion

1. Where do you get these materials from?
2. What is local material available and what are the materials brought from afar?
3. What is the advantage of using some materials, based on rates, with respect to hazard resistance?
4. How to convince the client regarding which material to use?

3. Material Manufacturing Unit

Visit to material manufacturing unit and discussion with the manufacturer for CSEB/ Fly-ash, precast units for roofing, etc.

Points for Discussion

1. Is this material suitable for the hazard-resistant construction prevalent in that region?
2. Where can this material be used- in walls, columns, foundations etc? Should it be used on the exterior or interior surface?
3. What are the pros and cons of using this material in that region?
4. What is its cost compared to alternative materials used in that region?

C15

Hazard-Resistant Features for Other Construction Elements

No. of Slides: 13
Time: 8 hours



National Disaster Management Authority



Unnati
Organisation for Development Education



People in Centre

Expected Outcomes

1. Participants know about aspects of hazard resistance in miscellaneous building elements.

What are the other elements in a house that we build apart from the foundations, plinths, walls, windows and roofs?



Some of the other typical elements in houses are:

1. Parapets
2. Balconies and Chajjas
3. Staircases
4. Verandah
5. Overhead tanks

(Add other elements to this list based on your region)

1. Parapets

- a) Parapet should be light weight. Avoid high parapets. The height should be appropriate for safety.
- b) Prefer railings over parapet walls in earthquake region.

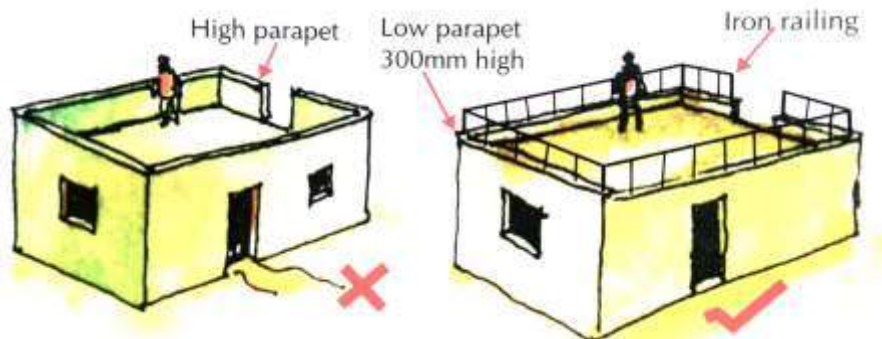

2. Balconies and Chajjas

Any kind of projections from the floor must be **properly secured** and **braced**.

- Limit the size of overhang. Preferably avoid overhangs over 900 mm.
- Provide brackets to support overhangs if needed.
- Reinforcement design in cantilevers should be on the upper side of the slab cross-section.
- Appropriate anchoring to the structure is must.



Height "h" of wall above the chajja must be equal to length "L" of projection unless there is heavy roof resting on wall.



Support beams must extend into walls $1\frac{1}{2}$ times length of projection.



For chhajja, roof and balcony projecting out less than 0.92m follow above instructions.

3. Staircase

A staircase is an important element of the house to connects two floors and is especially useful during floods when one needs to be on a higher level to protect oneself. For hazard resistance:

- The points at which the staircase meets the walls are critical.
- The junction where floor slab meets the staircase will be stressed as the shaking may cause the mass of the roof to crash into the staircase.

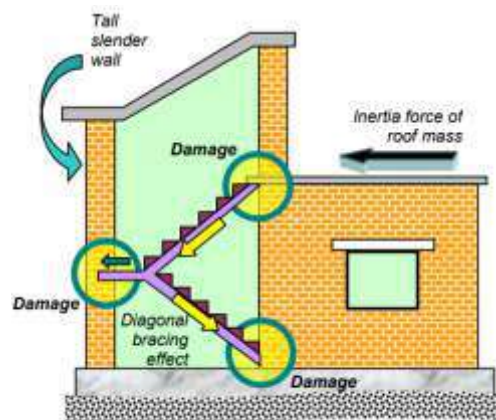

(a) Damage in building with rigidly built-in staircase

By separating the staircase from the main structure, we can avoid damage to main structure as well as to the staircase.

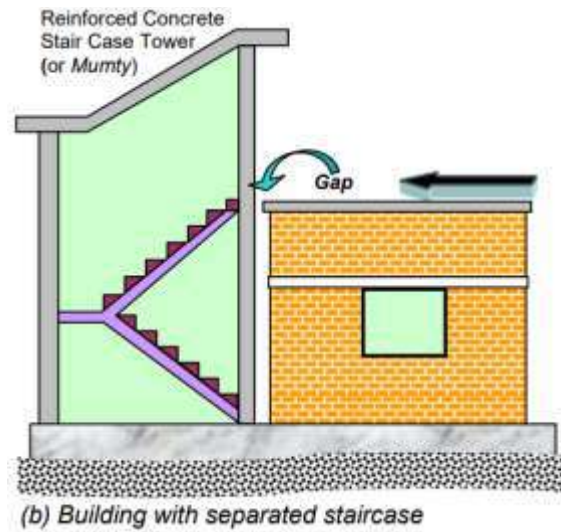

Alternatively, the staircase can be made of lighter materials and then anchored at the appropriate point on the floor slab and the floor.



4. Verandah

If the verandah is made by a projection of the floor slab of the house, the columns of the verandah will be taking the loads of the floor down to the ground.

The columns of the verandah should be properly anchored and braced. It must be anchored properly to the roof and plinth of the building so that it does not get unhinged.



C15 Hazard Resistant Features for Other Construction Elements

NDMA

Unnati

PIC

10

5. Overhead Tanks

Overhead tanks add extra weight to the top of the house and therefore increase the dead load of the roof. They cause the part of the house that supports, to be unevenly stressed. This causes damage to the house.

- a) The size of the tank must be optimum for use. **Do not oversize the tank.**
- b) **The tank should be preferably separate** (prefabricated/ ready-made) and not built with RC. Such tank will usually be light weight and will act as a separate unit and is not structurally integrated with the main structure. In this way, the displacement or damage will not involve main structure.
- c) The tank **should be placed on the walls** and not in the centre of the slab such that load transfer is directly on the walls.
- d) To build an RC tank, consult an Engineer.

C15 Hazard Resistant Features for Other Construction Elements

NDMA

Unnati

PIC

11

Other things to keep in mind while building a hazard resistant house

- e) **Electricals:** To avoid electrocution during a hazard, electric wires must be kept in a waterproof duct.
- f) **Plumbing:** To avoid spread of disease, sewage plumbing pipes should be of good quality and must avoid leakage. Soak Pits should be away from foundations and water source.

Summary

1. Parapets must be light weight.
2. Size of overhangs (balconies, Chajjas etc.) must be limited to 900 mm and must be properly braced.
3. Staircases, if made of heavy materials, should be built at a certain gap from the main house.
4. Verandah should have columns that are properly braced to carry roof loads.
5. Overhead tanks must be preferably separate from main structure and placed on the walls, not in the centre of the slab to allow effective load transfer.

C16

Estimation of Quantities and Costs

No. of Slides: 7

Time: 1 hour



National Disaster Management Authority



Unnati

Organisation for Development Education



People in Centre

Expected Outcome

1. Participants are able to estimate cost of a house and implication of hazard resistant features on cost.

Example of Rate Chart for House with brick walls and an RC roof

Let's understand the cost of the house with following example.

Area of house: 215 sq. ft.

Total Cost of House: ₹ 75,000

Cost of house per square foot: ₹ 350

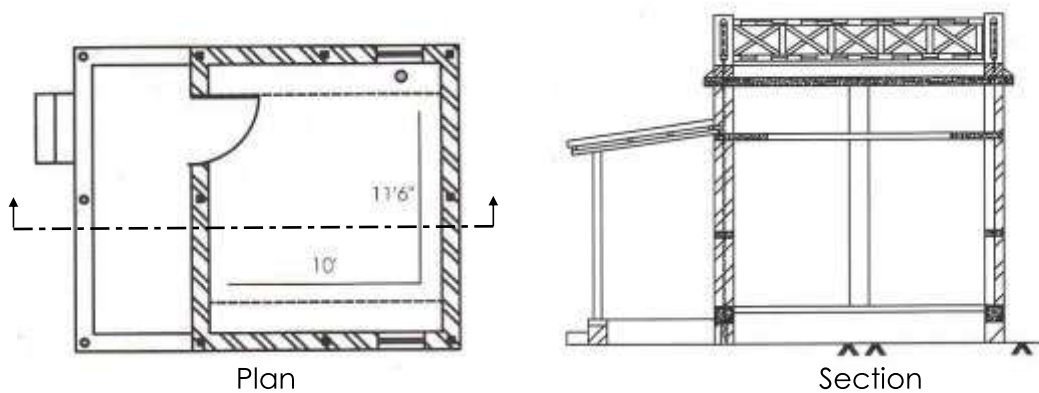

Costing estimate

1. Identify and list various hazard resistant features incorporated.
2. Calculate the cost addition for these features. Does it add significantly to overall cost of the house? Yes / No
3. What are the elements that could have been avoided or changed in order to add another resistant feature?
4. Total Cost without Hazard Resistant Features : _____
5. Total Extra Cost with Hazard Resistant Features : _____
6. Cost per square foot with Hazard Resistant Features : _____

Summary

1. Listing various elements of construction with quantities and costs for a house, with brick walls and RC roof, as an example.
2. Preparing Cost Estimate by listing, materials, rates and costs, based on rates of materials collected from local market and participants' and trainers' knowledge.
3. Discussing incorporation of various hazard resistant features and their implications on overall cost.

C17

Clarification of Questions

No. of Slides: 7

Time: 1 hour



National Disaster Management Authority



Unnati

Organisation for Development Education



People in Centre

Expected Outcome

1. Questions of the participants about any aspect of Hazard Resistant Construction in the region are clarified including test questions.

RolePlay 1

To understand the implication of hazard resistant house building, lets play a game. Lets hear a story:

Once upon a time, there lived a man named Kishanlal. He was living in a small house that was built by his grandfather. Now, having saved money for the last ten years, he wanted to add to this house or build another house so his 2 sons and 2 daughters can live comfortably. This is his hard earned money, which he has saved over the last 20 years. He is extremely careful and wants to spend the least possible amount as he is saving for the weddings of his daughters.

Manohar is a mason who has recently come back to the village after having done the 'Training of Masons on Hazard Resistant Construction'. He is excited to try building with all the new knowledge that he has recently acquired.

Now let's act out their conversation. Two participants who want to try the act and build the conversation Manohar and Kishanlal have about building the new house can come forward.

How can Manohar be successful in convincing Kishanlal to build at an added cost to ensure that his house is safe during a hazard?

What could Manohar have added to this conversation?

How could Manohar have dealt with this situation differently to be able to convince Kishanlal?

Why is it important that Manohar convince Kishanlal to build a hazard resistant house?

RolePlay 2

Mitul and Jaggi are two masons who work in the same village. They often work together. Sometimes, they use materials that are of a low quality for their clients to make the house cheaper for their clients.

Mitul goes for the 'Training of masons on Hazard Resistant Construction'. He realizes how dangerous using low quality materials and techniques can be. He comes back to aggi who is on his way to meet a new and famously shrewd client. Jaggi listens to Mitul's concerns about using good materials but knows that quoting a higher price than their competitors might cause him to lose the project. How will Mitul convince Jaggi and also convince the new client to spend a little more money to be able to build a safe house.

Now let's act out their conversation. Three participants who want to try the act and build the conversation between Mitul and Jaggi and then between Jaggi and the new client.

Was Mitul successful in convincing Jaggi to speak to the new client about spending more money to be able to build a safe house?

Were Jaggi and Mitul convincing enough to ensure the new client would be willing to spend extra on his new house to ensure it is hazard resistant?

What could have been added in these conversations?

Clarifications

- Is there any other situation that was not discussed during training, which you have faced or might face while building Hazard Resistant houses?
- Is there any situation which you foresee which may stop you from being able to implement any of the things you have learnt in this training program?
- Any other question or suggestion regarding the training program itself?

C18

Concluding Session

No. of Slides: 9
Time: 2 hours



National Disaster Management Authority



Unnati
Organisation for Development Education



People in Centre

Expected Outcomes

1. Feedback for the trainers, trainees and the training session is collected.
2. Trainee manual is handed out and its use is explained.
3. Certificates are distributed.

C18 Concluding Session

NDMA

Unnati

PIC

2

Training Feedback

1. Looking back at the first day's pin-up cards, detailing expectations of each of the trainees, and assessing if they have been met.
2. Each trainer and participant shares one thing they have learnt during training (this should be listed on board).
3. How will they implement/ incorporate it's application in their work?

C18 Concluding Session

NDMA

Unnati

PIC

3

Trainer Feedback

1. Were the expectations of the trainees met?
2. Were the theoretical sessions more enjoyable or the practical ones?
3. Which session was hard to understand?
4. Was the time available enough for each session?
5. What parts of the training would help the trainees in their future engagement in construction?

Trainer's Observations

1. Trainers talk about the response of the trainees, of the parts where the trainees responded well, and when the trainers' expectations were not met well.
2. Suggestions for the trainees, where they can improvise further through the training hand-out.

Distribution of Hand-outs

1. The trainers distribute the training hand-outs amongst the trainees.
2. The trainers show the content, and demonstrate how to use it, to facilitate their daily work.

C18 Concluding Session

NDMA

Unnati

PIC

6

Certificate Distribution

C18 Concluding Session

NDMA

Unnati

PIC

7

Congratulations!

**You are now ready to start your journey to building safer houses.
Thank you for being part of this training!**

You are now going to be :

1. More observant,
2. More careful with quality of materials and equipment,
3. Building safer houses, and
4. Guiding Clients and Co-workers in the right direction.

Acknowledgements

We would like to thank,

All those who have managed the logistics of this training.

All those who served us lunch and tea.

Participants for being here.

Those who have inspired this training and

All those who have helped make this training program.

5. Bibliography

- Agarwal, Ankush. Cyclone Resistant Building Architecture. 1st ed. UNDP, 2007.
- Arya , A.S, 2001. Guidelines for Cyclone Resistant Construction of Buildings In Gujarat. 1st ed. Gandhinagar: GSDMA.
- Arya, Anand S. and Ankush Agarwal. Multi-Hazard Resistant New Construction Or Reconstruction Of BPL Houses In Flood Prone Alluvial Areas. 1st ed. New Delhi: UNDP Disaster Risk Management Program, New Delhi.
- Baker, Laurie. Brick. 1st ed. Thissur: Centre for Science and Technology of Rural Development, 1988.
- Baker, Laurie. MUD. 1st ed. Thrissur: Center For Science and Technology for Rural Development, 1988.
- Baker, Laurie and Chandra Dath. Earthquake. 1st ed. Centre for Science and Technology for Rural Development, 1992.
- Bachmann, Hugo. Seismic Conceptual Design Of Buildings – Basic Principles For Engineers, Architects, Building Owners, And Authorities. 1st ed. Biel: Swiss Federal Office for Water and Geology Swiss Agency for Development and Cooperation, 2003.
- Brzev, Svetlana and Roberto Meli. Seismic Design Guide For Low-Rise Confined Masonry Buildings. 1st ed. Confined Masonry Network A Project of the World Housing Encyclopedia, EERI & IAEE, 2011.
- C.V.R Murty . 2005. IITK-BMTPC Earthquake Tips. [ONLINE] Available at: <http://www.iitk.ac.in/nicee/EQTips/EQTip01.pdf>. [Accessed 15 December 2016].
- Indira Awaas Yojana, Ready Reckoner for masons . 1st ed. India: Ministry for Rural Development
- Guidelines For Earthquake Resistant Non-Engineered Construction. 1st ed. National Information Center of Earthquake Engineering of India (NICEE), 2004.
- Jain, Sudhir K. "Indian Earthquakes : An Overview". The Indian Concrete Journal 72.11 (1998): n. pag.
- National Disaster Management Guidelines—Management of Floods, 2008. A publication of the National Disaster Management Authority, Government of India. January 2008, New Delhi.
- Minke, Gernot. Construction Manual For Earthquake Resistant Houses Made Of Earth. 1st ed. GATE- BASIN(Building Advisory Service and Information Network) at GTZ-GmbH (: N.p., 2001.
- Rajendra Desai, Rupal Desai , R. D, 2008. Manual on Hazard Resistant Construction in India. 1st ed. Ahmedabad : UNDP.



Unnati

Organisation for Development Education



People in Centre